

N-Channel Logic Level Enhancement Mode Field Effect Transistor

Product Summary:

BV_{DSS}	60V
$R_{DS(on)}$ (MAX.)	6m Ω
I_D	125A

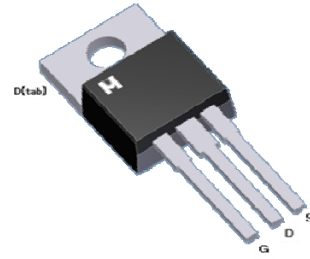
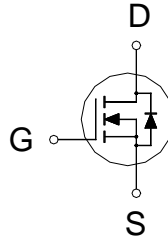

UIS, R_g 100% Tested

Pb-Free Lead Plating & Halogen Free



ABSOLUTE MAXIMUM RATINGS ($T_A = 25^\circ\text{C}$ Unless Otherwise Noted)

PARAMETERS/TEST CONDITIONS		SYMBOL	LIMITS	UNIT
Gate-Source Voltage		V_{GS}	± 20	V
Continuous Drain Current	$T_C = 25^\circ\text{C}$	I_D	125	A
	$T_C = 100^\circ\text{C}$		90	
Pulsed Drain Current ¹		I_{DM}	500	
Avalanche Current		I_{AS}	80	
Avalanche Energy	$L = 0.1\text{mH}$, $I_{AS}=80\text{A}$, $R_G=25\Omega$	E_{AS}	320	mJ
Repetitive Avalanche Energy ²	$L = 0.05\text{mH}$	E_{AR}	160	
Power Dissipation	$T_C = 25^\circ\text{C}$	P_D	166	W
	$T_C = 100^\circ\text{C}$		68	
Operating Junction & Storage Temperature Range		T_{j} , T_{stg}	-55 to 150	$^\circ\text{C}$

100% UIS testing in condition of $V_D=30\text{V}$, $L=0.1\text{mH}$, $V_G=10\text{V}$, $I_L=50\text{A}$, Rated $V_{DS}=60\text{V}$ N-CH

THERMAL RESISTANCE RATINGS

THERMAL RESISTANCE	SYMBOL	TYPICAL	MAXIMUM	UNIT
Junction-to-Case	$R_{\theta JC}$		0.75	$^\circ\text{C} / \text{W}$
Junction-to-Ambient	$R_{\theta JA}$		62.5	

¹Pulse width limited by maximum junction temperature.

²Duty cycle $\leq 1\%$



ELECTRICAL CHARACTERISTICS (T_J = 25 °C, Unless Otherwise Noted)

PARAMETER	SYMBOL	TEST CONDITIONS	LIMITS			UNIT
			MIN	TYP	MAX	
STATIC						
Drain-Source Breakdown Voltage	V _{(BR)DSS}	V _{GS} = 0V, I _D = 250μA	60			V
Gate Threshold Voltage	V _{GS(th)}	V _{DS} = V _{GS} , I _D = 250μA	2	3	4	
Gate-Body Leakage	I _{GSS}	V _{DS} = 0V, V _{GS} = ±20V			±100	nA
Zero Gate Voltage Drain Current	I _{DSS}	V _{DS} = 48V, V _{GS} = 0V			1	μA
		V _{DS} = 40V, V _{GS} = 0V, T _J = 125 °C			25	
On-State Drain Current ¹	I _{D(ON)}	V _{DS} = 10V, V _{GS} = 10V	125			A
Drain-Source On-State Resistance ¹	R _{DS(ON)}	V _{GS} = 10V, I _D = 30A		5.0	6.0	mΩ
Forward Transconductance ¹	g _{fs}	V _{DS} = 5V, I _D = 30A		52		S
DYNAMIC						
Input Capacitance	C _{iss}	V _{GS} = 0V, V _{DS} = 25V, f = 1MHz		3057		pF
Output Capacitance	C _{oss}			441		
Reverse Transfer Capacitance	C _{rss}			112		
Gate Resistance	R _g	V _{GS} = 15mV, V _{DS} = 0V, f = 1MHz		2.7		Ω
Total Gate Charge ^{1,2}	Q _g	V _{DS} = 30V, V _{GS} = 10V, I _D = 30A		40		nC
Gate-Source Charge ^{1,2}	Q _{gs}			17		
Gate-Drain Charge ^{1,2}	Q _{gd}			11		
Turn-On Delay Time ^{1,2}	t _{d(on)}	V _{DS} = 30V, I _D = 1A, V _{GS} = 10V, R _{GS} = 6Ω		20		nS
Rise Time ^{1,2}	t _r			75		
Turn-Off Delay Time ^{1,2}	t _{d(off)}			110		
Fall Time ^{1,2}	t _f			85		
SOURCE-DRAIN DIODE RATINGS AND CHARACTERISTICS (T_C = 25 °C)						
Continuous Current	I _S				125	A
Pulsed Current ³	I _{SM}				500	
Forward Voltage ¹	V _{SD}	I _F = 30A, V _{GS} = 0V			1.3	V
Reverse Recovery Time	t _{rr}	I _F = 25A, dI _F /dt = 100A / μS		35		nS
Reverse Recovery Charge	Q _{rr}			160		nC

¹Pulse test : Pulse Width ≤ 300 μsec, Duty Cycle ≤ 2%.

²Independent of operating temperature.

³Pulse width limited by maximum junction temperature.

Ordering & Marking Information:

Device Name: EMD06N06E for TO-220

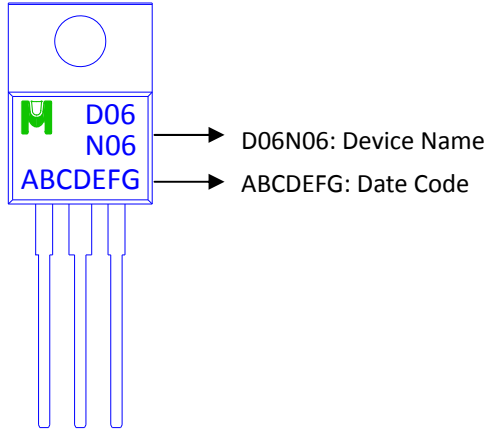



TYPICAL CHARACTERISTICS

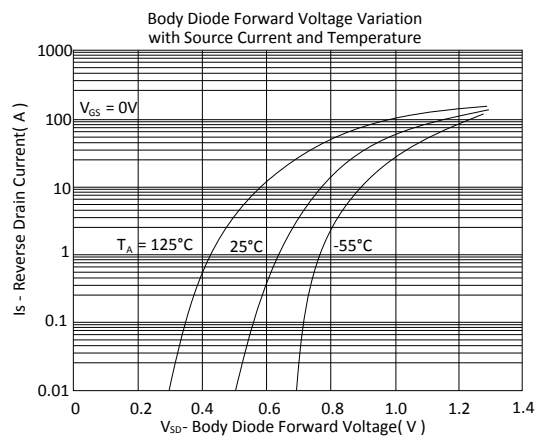
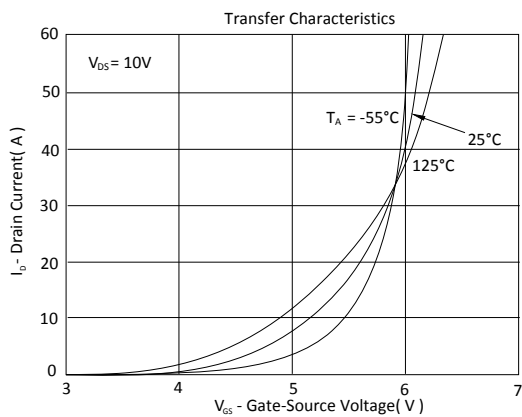
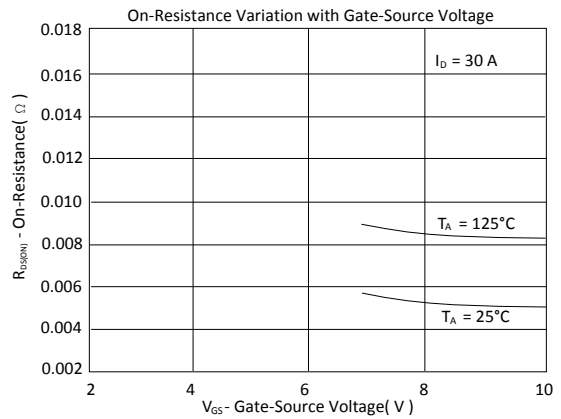
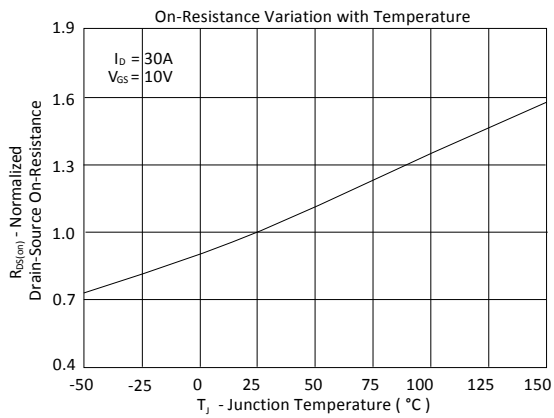
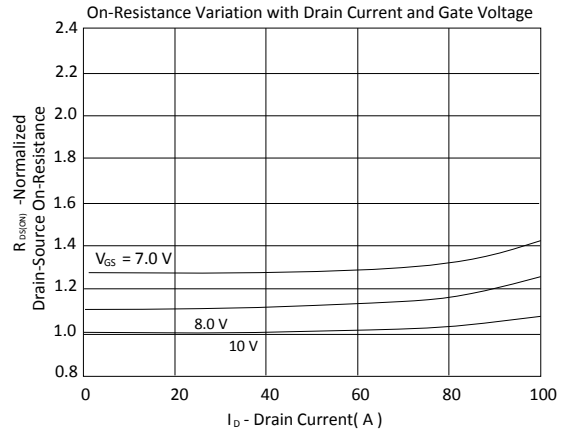
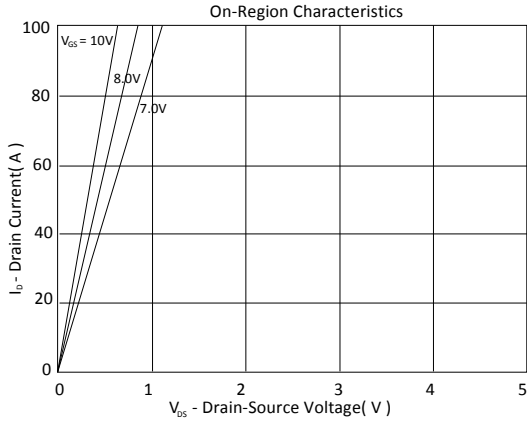

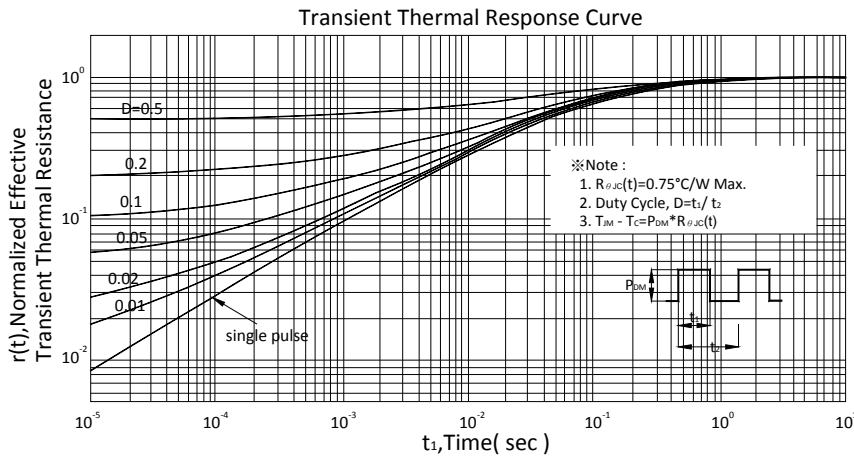
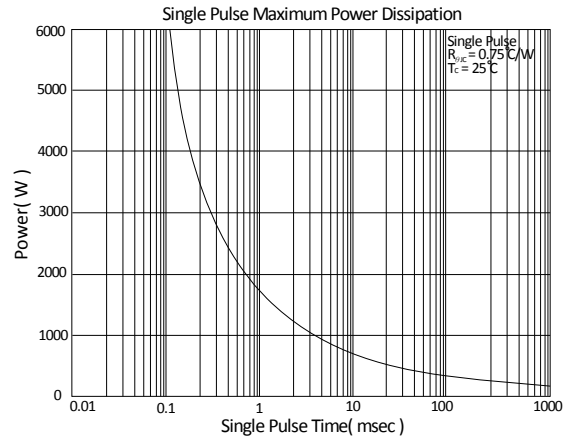
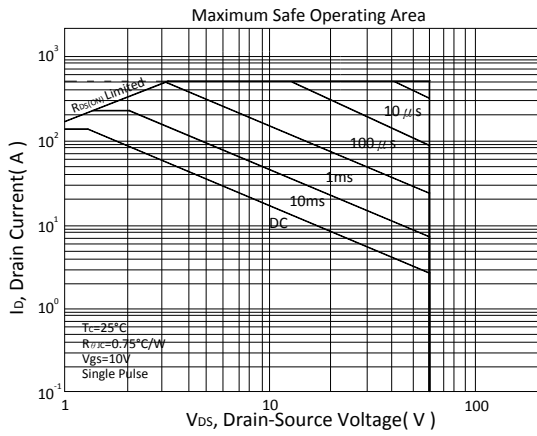
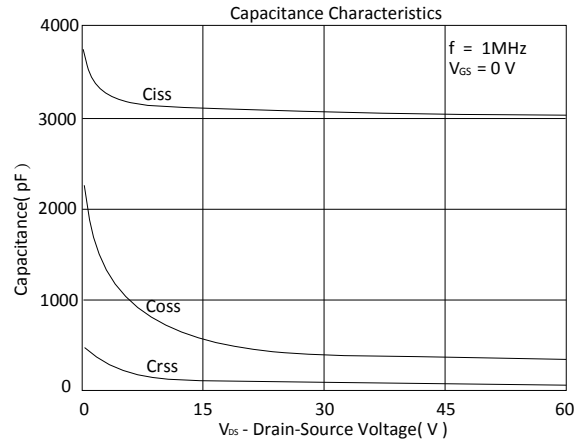
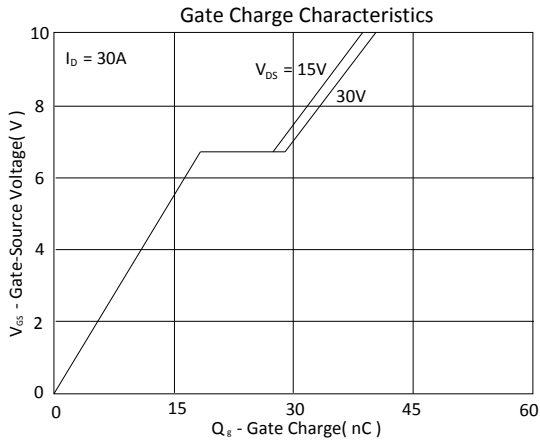



Outline Drawing

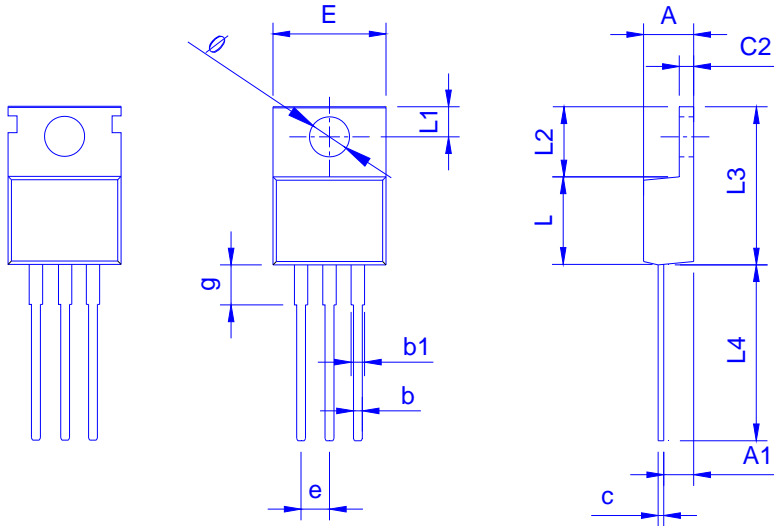

Dimension in mm

Dimension	A	A1	b	b1	c	c2	E	L	L1	L2	L3	L4	∅	e	g
Min.	4.07	2.04	0.60	1.15	0.31	1.11	9.90	8.30	2.50	6.00	14.30	12.70	3.40	2.04	2.85
Typ.	4.44	2.40	0.80	1.27	-	1.27	10.16	-	2.74	6.30	15.00	13.40	3.84	2.54	3.71
Max.	4.82	3.00	1.00	1.75	0.65	1.41	11.50	9.75	3.25	6.80	16.90	14.50	4.00	3.04	4.10