

N-Channel Logic Level Enhancement Mode Field Effect Transistor

Product Summary:

$BV_{DSS}$	60V
$R_{DS(on)}$ (MAX.)	60m $\Omega$
$I_D$	12A

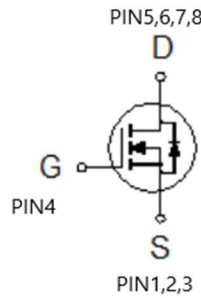

N Channel MOSFET

UIS, R<sub>g</sub> 100% Tested

Pb-Free Lead Plating & Halogen Free



ABSOLUTE MAXIMUM RATINGS ( $T_A = 25\text{ }^\circ\text{C}$  Unless Otherwise Noted)

PARAMETERS/TEST CONDITIONS		SYMBOL	LIMITS	UNIT
Gate-Source Voltage		$V_{GS}$	$\pm 20$	V
Continuous Drain Current	$T_C = 25\text{ }^\circ\text{C}$	$I_D$	12	A
	$T_A = 25\text{ }^\circ\text{C}$		6	
	$T_C = 100\text{ }^\circ\text{C}$		9	
Pulsed Drain Current <sup>1</sup>		$I_{DM}$	48	
Avalanche Current		$I_{AS}$	12	
Avalanche Energy	$L = 0.1\text{mH}$ , $I_{AS}=12\text{A}$ , $R_G=25\Omega$	$E_{AS}$	7.2	mJ
Repetitive Avalanche Energy <sup>2</sup>	$L = 0.05\text{mH}$	$E_{AR}$	3.6	
Power Dissipation	$T_C = 25\text{ }^\circ\text{C}$	$P_D$	21	W
	$T_C = 100\text{ }^\circ\text{C}$		8.3	
Power Dissipation	$T_A = 25\text{ }^\circ\text{C}$	$P_D$	2.5	W
	$T_A = 100\text{ }^\circ\text{C}$		1	
Operating Junction & Storage Temperature Range		$T_j, T_{stg}$	-55 to 150	$^\circ\text{C}$

100% UIS testing in condition of  $V_D=30\text{V}$ ,  $L=0.1\text{mH}$ ,  $V_G=10\text{V}$ ,  $I_L=7.5\text{A}$ , Rated  $V_{DS}=60\text{V}$  N-CH

THERMAL RESISTANCE RATINGS

THERMAL RESISTANCE	SYMBOL	TYPICAL	MAXIMUM	UNIT
Junction-to-Case	$R_{\theta JC}$		6	$^\circ\text{C}/\text{W}$
Junction-to-Ambient <sup>3</sup>	$R_{\theta JA}$		50	

<sup>1</sup>Pulse width limited by maximum junction temperature.

<sup>2</sup>Duty cycle  $\leq 1\%$



<sup>3</sup>50°C / W when mounted on a 1 in<sup>2</sup> pad of 2 oz copper.

**ELECTRICAL CHARACTERISTICS (T<sub>J</sub> = 25 °C, Unless Otherwise Noted)**

PARAMETER	SYMBOL	TEST CONDITIONS	LIMITS			UNIT
			MIN	TYP	MAX	
<b>STATIC</b>						
Drain-Source Breakdown Voltage	V <sub>(BR)DSS</sub>	V <sub>GS</sub> = 0V, I <sub>D</sub> = 250μA	60			V
Gate Threshold Voltage	V <sub>GS(th)</sub>	V <sub>DS</sub> = V <sub>GS</sub> , I <sub>D</sub> = 250μA	1.0	2.0	3.2	
Gate-Body Leakage	I <sub>GSS</sub>	V <sub>DS</sub> = 0V, V <sub>GS</sub> = ±20V			±100	nA
Zero Gate Voltage Drain Current	I <sub>DSS</sub>	V <sub>DS</sub> = 48V, V <sub>GS</sub> = 0V			1	μA
		V <sub>DS</sub> = 40V, V <sub>GS</sub> = 0V, T <sub>J</sub> = 125 °C			25	
On-State Drain Current <sup>1</sup>	I <sub>D(ON)</sub>	V <sub>DS</sub> = 5V, V <sub>GS</sub> = 10V	12			A
Drain-Source On-State Resistance <sup>1</sup>	R <sub>DS(ON)</sub>	V <sub>GS</sub> = 10V, I <sub>D</sub> = 6A		50	60	mΩ
		V <sub>GS</sub> = 5V, I <sub>D</sub> = 5A		58	75	
Forward Transconductance <sup>1</sup>	g <sub>fs</sub>	V <sub>DS</sub> = 5V, I <sub>D</sub> = 6A		12		S
<b>DYNAMIC</b>						
Input Capacitance	C <sub>iss</sub>	V <sub>GS</sub> = 0V, V <sub>DS</sub> = 30V, f = 1MHz		633		pF
Output Capacitance	C <sub>oss</sub>			67		
Reverse Transfer Capacitance	C <sub>rss</sub>			44		
Total Gate Charge <sup>1,2</sup>	Q <sub>g</sub>	V <sub>DS</sub> = 30V, V <sub>GS</sub> = 10V, I <sub>D</sub> = 6A		13.8		nC
Gate-Source Charge <sup>1,2</sup>	Q <sub>gs</sub>			2.8		
Gate-Drain Charge <sup>1,2</sup>	Q <sub>gd</sub>			4.0		
Turn-On Delay Time <sup>1,2</sup>	t <sub>d(on)</sub>	V <sub>DS</sub> = 30V, I <sub>D</sub> = 1A, V <sub>GS</sub> = 10V, R <sub>GS</sub> = 6Ω		12		nS
Rise Time <sup>1,2</sup>	t <sub>r</sub>			8		
Turn-Off Delay Time <sup>1,2</sup>	t <sub>d(off)</sub>			20		
Fall Time <sup>1,2</sup>	t <sub>f</sub>			7		
<b>SOURCE-DRAIN DIODE RATINGS AND CHARACTERISTICS (T<sub>C</sub> = 25 °C)</b>						
Continuous Current	I <sub>S</sub>				12	A
Pulsed Current <sup>3</sup>	I <sub>SM</sub>				48	
Forward Voltage <sup>1</sup>	V <sub>SD</sub>	I <sub>F</sub> = 6A, V <sub>GS</sub> = 0V			1.2	V

<sup>1</sup>Pulse test : Pulse Width ≤ 300 μsec, Duty Cycle ≤ 2%.

<sup>2</sup>Independent of operating temperature.

<sup>3</sup>Pulse width limited by maximum junction temperature.

EMC will review datasheet by quarter, and update new version.



TYPICAL CHARACTERISTICS

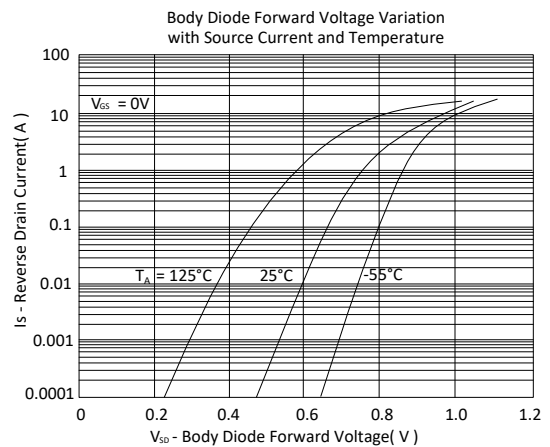
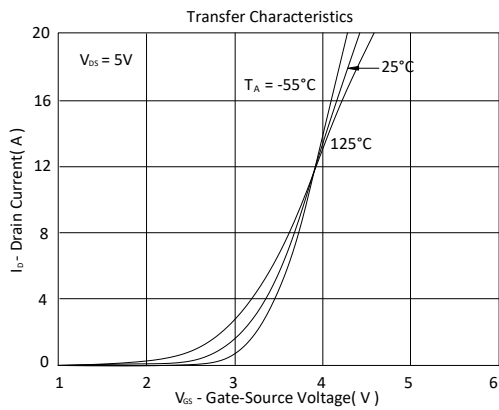
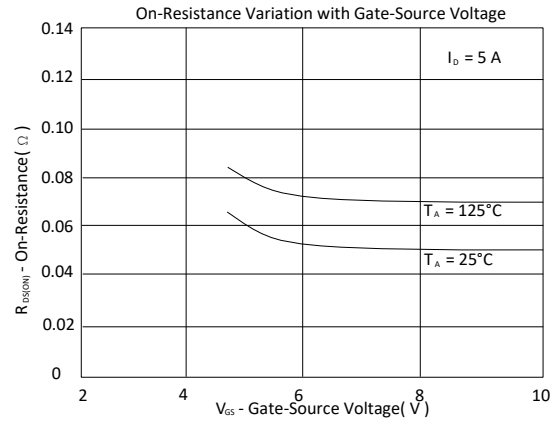
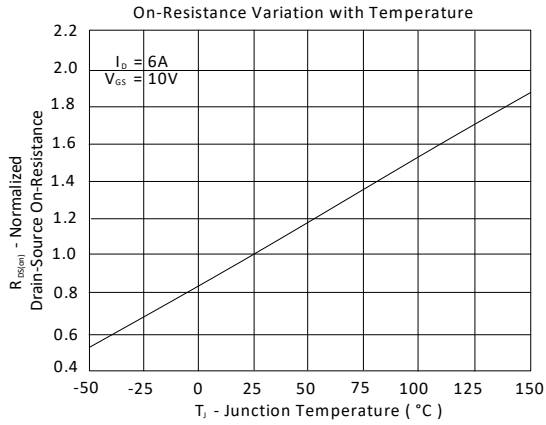
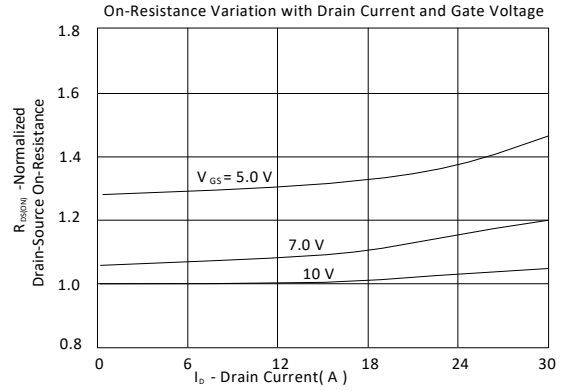
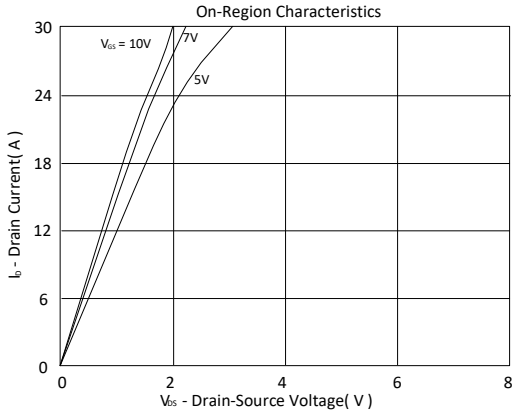

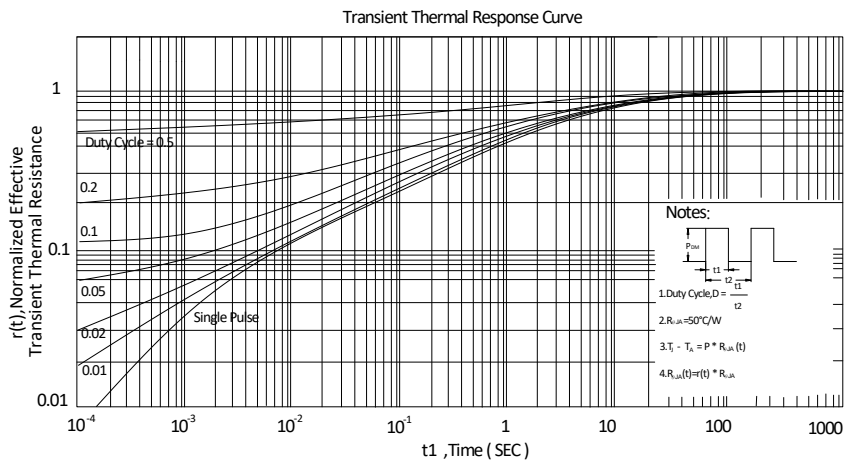
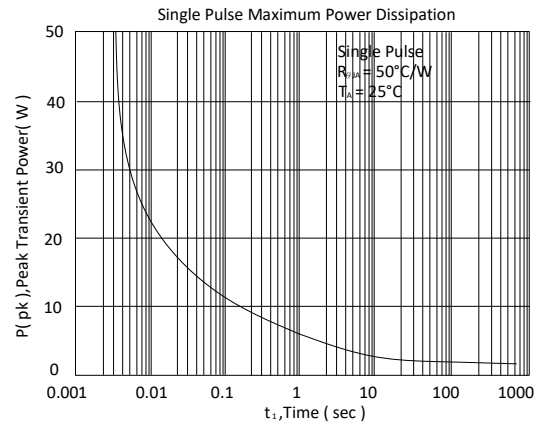
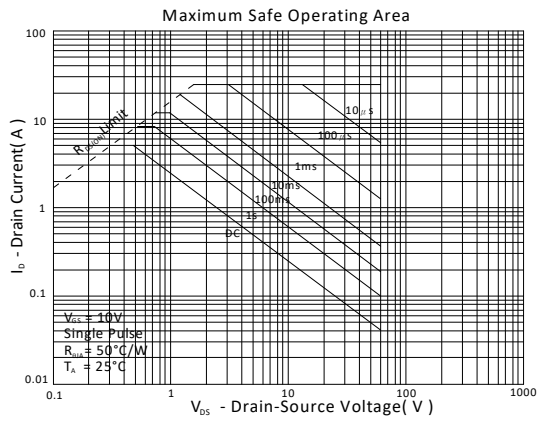
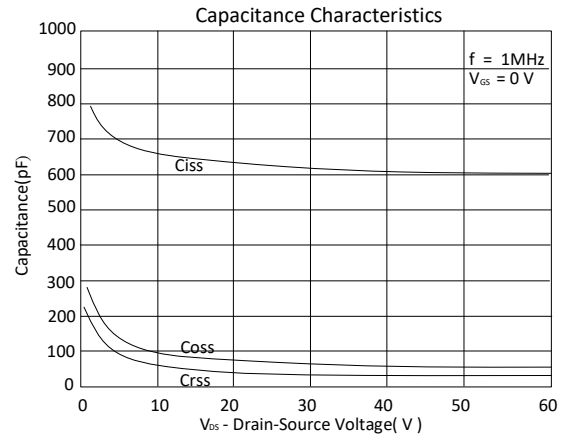
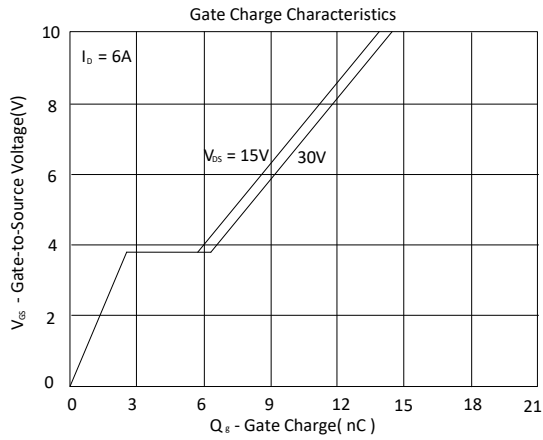

Ordering & Marking Information:

Device Name: EMB60N06V for EDFN 3 x 3



B60N06: Device Name

ABCDEFGH: Date Code

A: Assembly House

B: Year(A:2008 B:2009 C:2010....)

C: Month(A:01 B:02 C:03 D:04 E:05 F:06 G:07 H:08 I:09 J:10 K:11 L:12)

DEFG: Serial No.

Outline Drawing

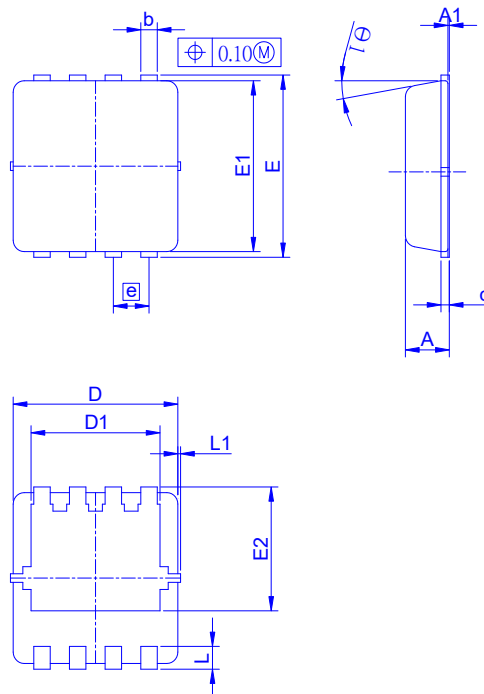

Dimension in mm

Dimension	A	A1	b	c	D	D1	E	E1	E2	e	L	L1	$\theta$
Min.	0.65	0	0.20	0.10	2.90	2.15	3.10	2.90	1.53	0.55	0.25	-	0°
Typ.	0.75	-	0.30	0.15	3.00	2.45	3.20	3.00	1.97	0.65	0.40	0.075	10°
Max.	0.90	0.05	0.40	0.25	3.30	2.74	3.50	3.30	2.59	0.75	0.60	0.150	14°

Recommended minimum pads

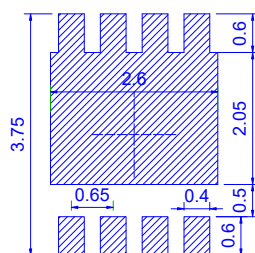



Tape&Reel Information: 5000pcs/Reel

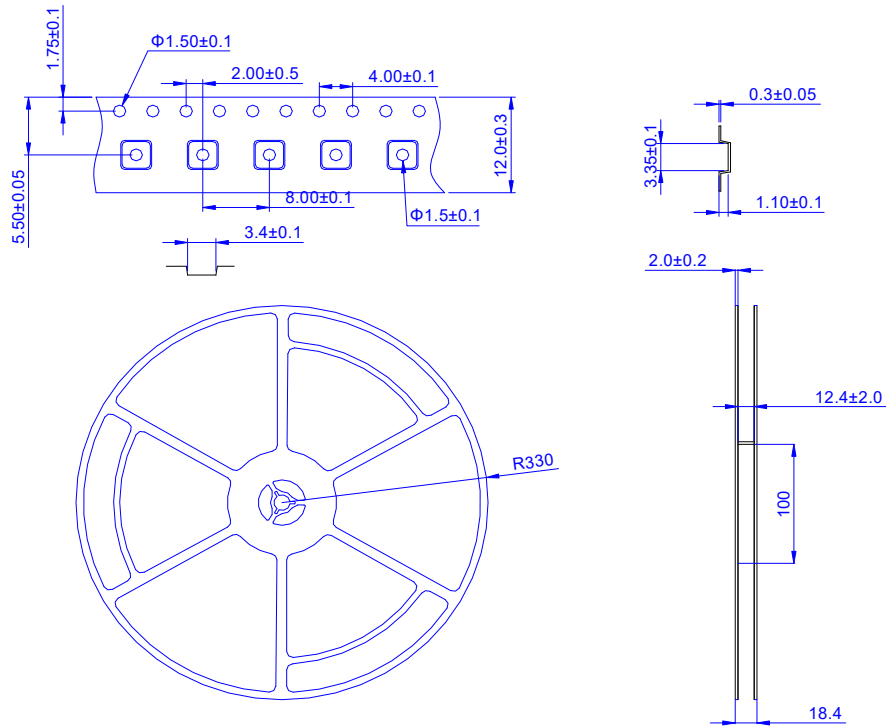

產品別	EDFN3X3
Reel 尺寸	13"
編帶方式	<p>FEEED DIRECTION</p>
前空格	50
後空格	50
裝箱數	
滿捲數量	5K
捲/內盒比	1 : 1
內盒滿箱數	5K
內/外箱比	10 : 1
外箱滿箱數	50K