

Dual N-Channel Logic Level Enhancement Mode Field Effect Transistor

Product Summary:

|                            |      |
|----------------------------|------|
| BV <sub>DSS</sub>          | 60V  |
| R <sub>DS(on)</sub> (MAX.) | 60mΩ |
| I <sub>D</sub>             | 6A   |

Dual N Channel MOSFET

UIS, R<sub>g</sub> 100% Tested

Pb-Free Lead Plating & Halogen Free

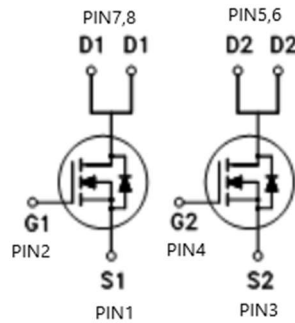

ABSOLUTE MAXIMUM RATINGS (T<sub>A</sub> = 25 °C Unless Otherwise Noted)

| PARAMETERS/TEST CONDITIONS                     |  | SYMBOL                            | LIMITS     | UNIT |
|--|--|-----------------------------------|------------|------|
| Gate-Source Voltage                            |  | V <sub>GS</sub>                   | ±20        | V    |
| Continuous Drain Current                       | T <sub>A</sub> = 25 °C                               | I <sub>D</sub>                    | 6          | A    |
|  | T <sub>A</sub> = 100 °C                              |                                   | 4.3        |      |
| Pulsed Drain Current <sup>1</sup>              |  | I <sub>DM</sub>                   | 24         |      |
| Avalanche Current                              |  | I <sub>AS</sub>                   | 12         |      |
| Avalanche Energy                               | L = 0.1mH, I <sub>AS</sub> =12A, R <sub>G</sub> =25Ω | E <sub>AS</sub>                   | 7.2        | mJ   |
| Repetitive Avalanche Energy <sup>2</sup>       | L = 0.05mH   | E <sub>AR</sub>                   | 3.6        |      |
| Power Dissipation                              | T <sub>A</sub> = 25 °C                               | P <sub>D</sub>                    | 2.27       | W    |
|  | T <sub>A</sub> = 100 °C                              |                                   | 0.9        |      |
| Operating Junction & Storage Temperature Range |  | T <sub>J</sub> , T <sub>stg</sub> | -55 to 150 | °C   |

100% UIS testing in condition of V<sub>D</sub>=30V, L=0.1mH, V<sub>G</sub>=10V, I<sub>L</sub>=7.5A, Rated V<sub>DS</sub>=60V N-CH

THERMAL RESISTANCE RATINGS

| THERMAL RESISTANCE               | SYMBOL           | TYPICAL | MAXIMUM | UNIT   |
|----------------------------------|------------------|---------|---------|--------|
| Junction-to-Case                 | R <sub>θJC</sub> |         | 7.5     | °C / W |
| Junction-to-Ambient <sup>3</sup> | R <sub>θJA</sub> |         | 55      |        |

<sup>1</sup>Pulse width limited by maximum junction temperature.

<sup>2</sup>Duty cycle ≤ 1%

<sup>3</sup>55°C / W when mounted on a 1 in<sup>2</sup> pad of 2 oz copper.



ELECTRICAL CHARACTERISTICS (T<sub>J</sub> = 25 °C, Unless Otherwise Noted)

| PARAMETER   | SYMBOL                                 | TEST CONDITIONS  | LIMITS   |      |      | UNIT |
|---|--|--|--|------|------|------|
|   |  |  | MIN  | TYP  | MAX  |      |
| <b>STATIC</b>   |  |  |  |      |      |      |
| Drain-Source Breakdown Voltage  | V <sub>(BR)DSS</sub>                   | V <sub>GS</sub> = 0V, I <sub>D</sub> = 250μA                         | 60   |      |      | V    |
| Gate Threshold Voltage  | V <sub>GS(th)</sub>                    | V <sub>DS</sub> = V <sub>GS</sub> , I <sub>D</sub> = 250μA           | 1.0  | 2.0  | 3.2  |      |
| Gate-Body Leakage   | I <sub>GSS</sub>                       | V <sub>DS</sub> = 0V, V <sub>GS</sub> = ±20V                         |  |      | ±100 | nA   |
| Zero Gate Voltage Drain Current   | I <sub>DSS</sub>                       | V <sub>DS</sub> = 48V, V <sub>GS</sub> = 0V                          |  |      | 1    | μA   |
|   |  | V <sub>DS</sub> = 40V, V <sub>GS</sub> = 0V, T <sub>J</sub> = 125 °C |  |      | 25   |      |
| On-State Drain Current <sup>1</sup>   | I <sub>D(ON)</sub>                     | V <sub>DS</sub> = 10V, V <sub>GS</sub> = 10V                         | 6  |      |      | A    |
| Drain-Source On-State Resistance <sup>1</sup>                                 | R <sub>DS(ON)</sub>                    | V <sub>GS</sub> = 10V, I <sub>D</sub> = 6A                           |  | 50   | 60   | mΩ   |
|   |  | V <sub>GS</sub> = 4.5V, I <sub>D</sub> = 4A                          |  | 70   | 85   |      |
| Forward Transconductance <sup>1</sup>   | g <sub>fs</sub>                        | V <sub>DS</sub> = 5V, I <sub>D</sub> = 6A                            |  | 13   |      | S    |
| <b>DYNAMIC</b>  |  |  |  |      |      |      |
| Input Capacitance   | C <sub>iss</sub>                       | V <sub>GS</sub> = 0V, V <sub>DS</sub> = 30V, f = 1MHz                |  | 633  |      | pF   |
| Output Capacitance  | C <sub>oss</sub>                       |  |  | 67   |      |      |
| Reverse Transfer Capacitance  | C <sub>rss</sub>                       |  |  | 44   |      |      |
| Gate Resistance   | R <sub>g</sub>                         | V <sub>GS</sub> = 15mV, V <sub>DS</sub> = 0V, f = 1MHz               |  | 2.5  |      | Ω    |
| Total Gate Charge <sup>1,2</sup>  | Q <sub>g</sub> (V <sub>GS</sub> =10V)  | V <sub>DS</sub> = 30V, V <sub>GS</sub> = 10V,<br>I <sub>D</sub> = 6A |  | 13.8 |      | nC   |
|   | Q <sub>g</sub> (V <sub>GS</sub> =4.5V) |  |  | 7.2  |      |      |
| Gate-Source Charge <sup>1,2</sup>   | Q <sub>gs</sub>                        |  |  | 2.8  |      |      |
| Gate-Drain Charge <sup>1,2</sup>  | Q <sub>gd</sub>                        |  |  | 4.0  |      |      |
| Turn-On Delay Time <sup>1,2</sup>   | t <sub>d(on)</sub>                     |  | V <sub>DS</sub> = 30V,<br>I <sub>D</sub> = 1A, V <sub>GS</sub> = 10V, R <sub>GS</sub> = 6Ω |      | 10   |      |
| Rise Time <sup>1,2</sup>  | t <sub>r</sub>                         |  |  | 7.5  |      |      |
| Turn-Off Delay Time <sup>1,2</sup>  | t <sub>d(off)</sub>                    |  |  | 15   |      |      |
| Fall Time <sup>1,2</sup>  | t <sub>f</sub>                         |  |  | 10   |      |      |
| <b>SOURCE-DRAIN DIODE RATINGS AND CHARACTERISTICS (T<sub>A</sub> = 25 °C)</b> |  |  |  |      |      |      |
| Continuous Current  | I <sub>s</sub>                         |  |  |      | 2.3  | A    |
| Pulsed Current <sup>3</sup>   | I <sub>SM</sub>                        |  |  |      | 9.2  |      |
| Forward Voltage <sup>1</sup>  | V <sub>SD</sub>                        | I <sub>F</sub> = I <sub>s</sub> , V <sub>GS</sub> = 0V               |  |      | 1.2  | V    |
| Reverse Recovery Time   | t <sub>rr</sub>                        | I <sub>F</sub> = I <sub>s</sub> , dI <sub>F</sub> /dt = 100A / μS    |  | 15   |      | nS   |
| Reverse Recovery Charge   | Q <sub>rr</sub>                        |  |  | 8    |      | nC   |

<sup>1</sup>Pulse test : Pulse Width ≤ 300 μsec, Duty Cycle ≤ 2%.

<sup>2</sup>Independent of operating temperature.

<sup>3</sup>Pulse width limited by maximum junction temperature.

EMC will review datasheet by quarter, and update new version.



TYPICAL CHARACTERISTICS

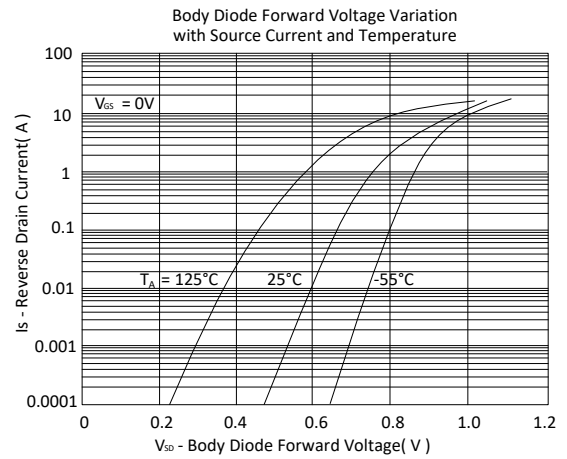
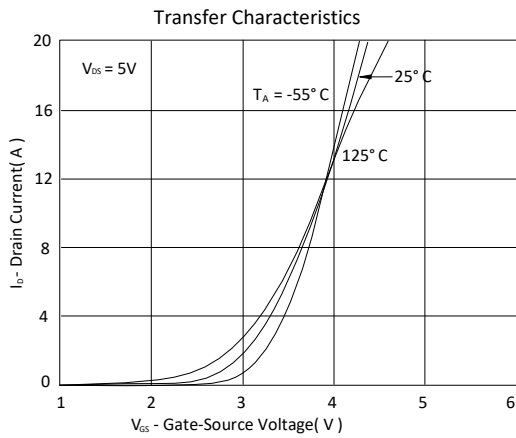
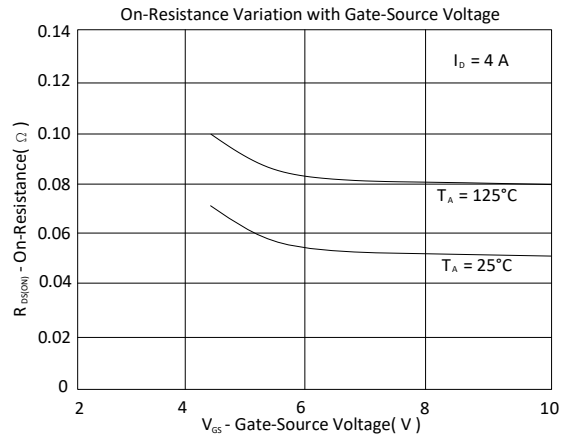
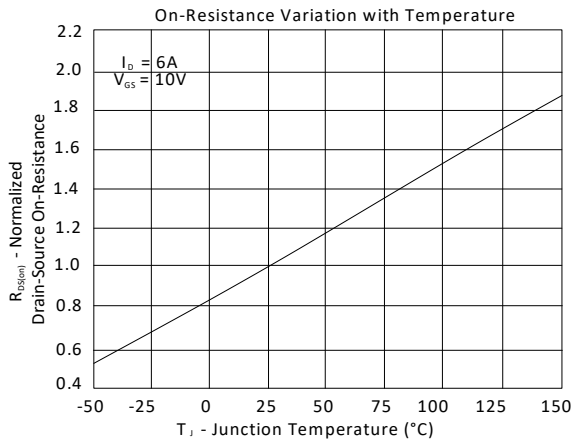
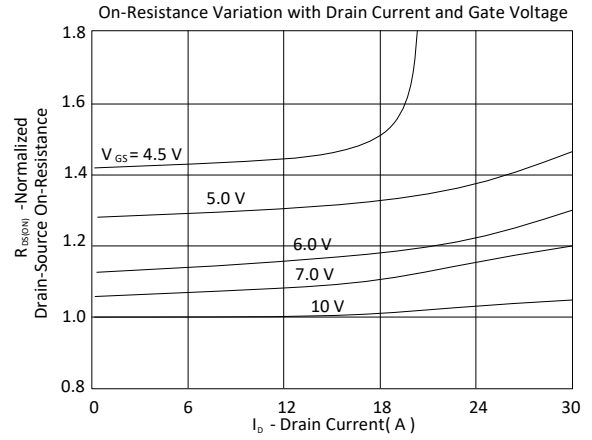
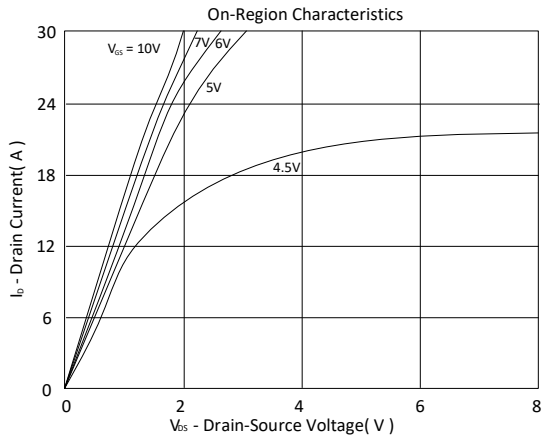

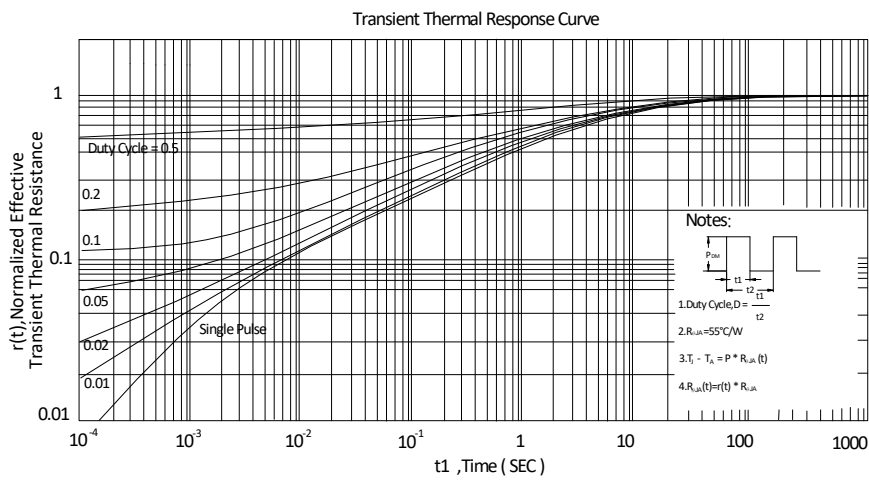
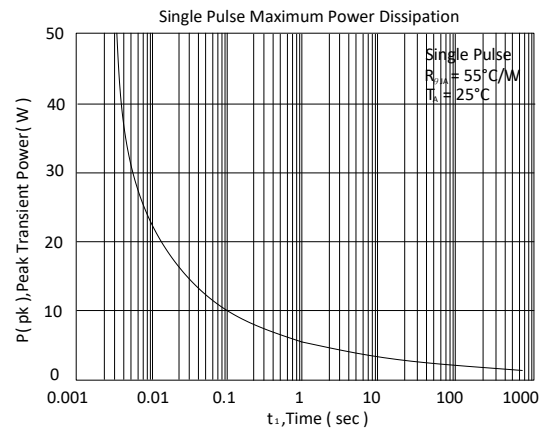
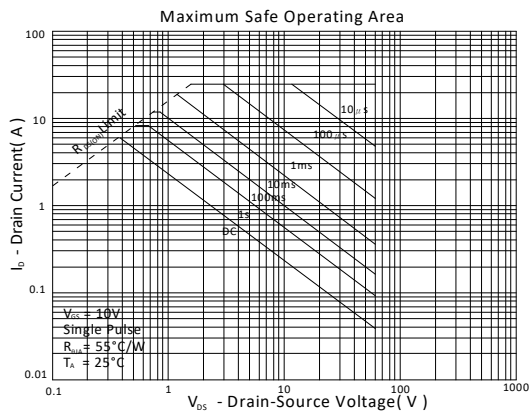
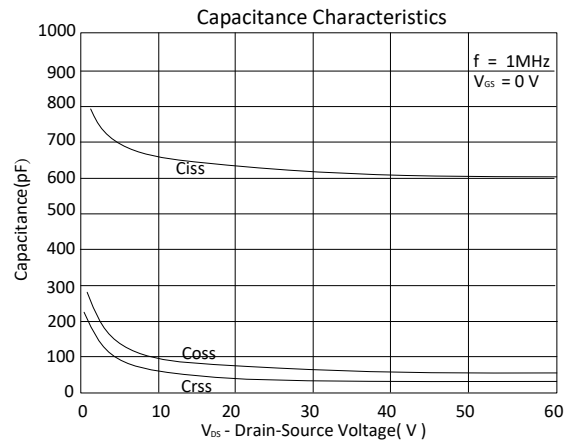
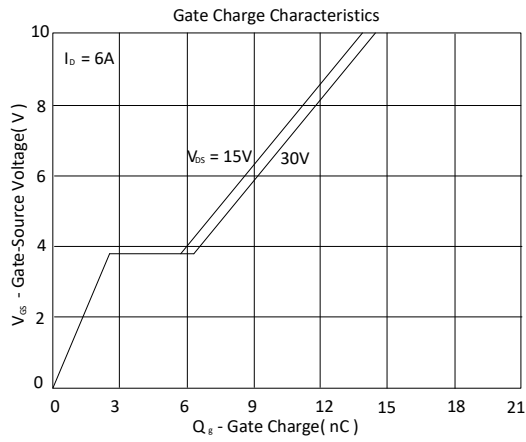

Ordering & Marking Information:

Device Name: EMB60A06V for EDFN3X3



EMB60A06V: Device Name

ABCDEFGH: Date Code

A: Assembly House

B: Year(A:2008 B:2009 C:2010....)

C: Month(A:01 B:02 C:03 D:04 E:05 F:06 G:07 H:08 I:09 J:10 K:11 L:12)

DEFG: Serial No.

Outline Drawing

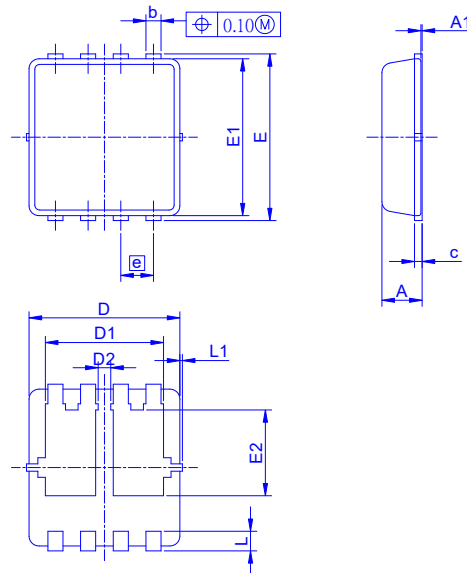

Dimension in mm

| Dimension | A    | A1   | b    | c    | D    | D1   | D2   | E    | E1   | E2   | e    | L    | L1    | θ1  |
|-----------|------|------|------|------|------|------|------|------|------|------|------|------|-------|-----|
| Min.      | 0.65 | 0    | 0.20 | 0.10 | 2.90 | 2.15 | 0.28 | 3.10 | 2.90 | 1.53 | 0.55 | 0.30 | -     | 0°  |
| Typ.      | 0.75 | -    | 0.30 | 0.15 | 3.00 | 2.47 | 0.38 | 3.20 | 3.00 | 1.81 | 0.65 | 0.40 | 0.075 | 10° |
| Max.      | 0.90 | 0.05 | 0.40 | 0.25 | 3.30 | 2.75 | -    | 3.50 | 3.30 | 1.98 | 0.75 | 0.50 | 0.150 | 14° |

Recommended minimum pads

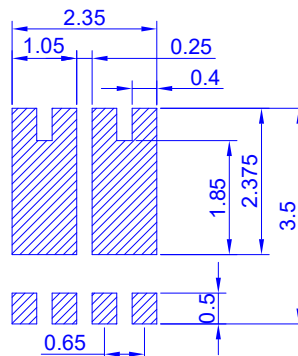



Tape&Reel Information: 5000pcs/Reel

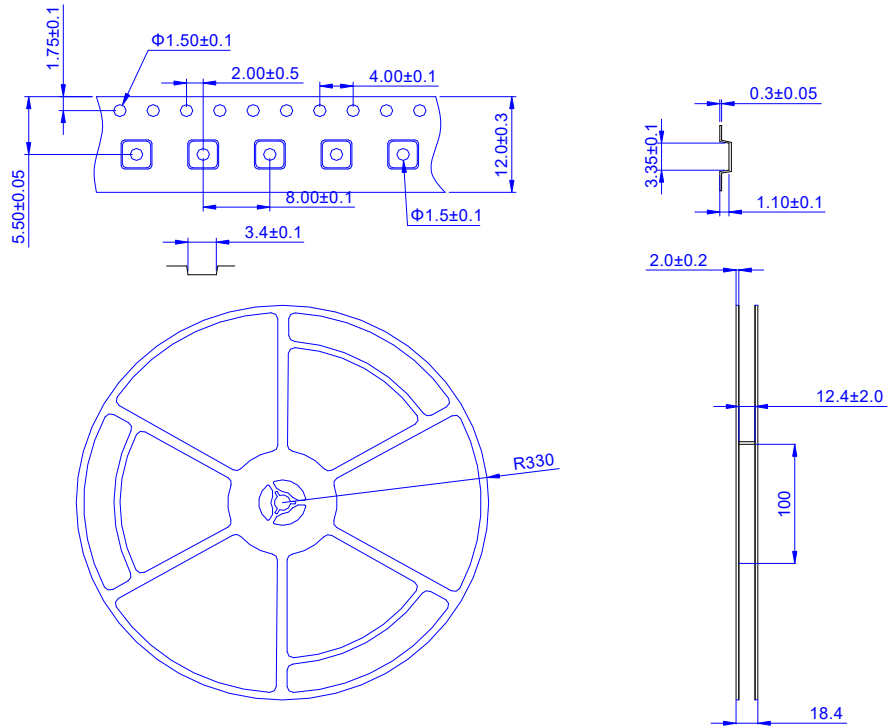

|         |                        |
|---------|------------------------|
| 產品別     | EDFN3X3                |
| Reel 尺寸 | 13"                    |
| 編帶方式    | <p>FEEED DIRECTION</p> |
| 前空格     | 50                     |
| 後空格     | 50                     |
| 裝箱數     |                        |
| 滿捲數量    | 5K                     |
| 捲/內盒比   | 1 : 1                  |
| 內盒滿箱數   | 5K                     |
| 內/外箱比   | 10 : 1                 |
| 外箱滿箱數   | 50K                    |