

Dual N-Channel Logic Level Enhancement Mode Field Effect Transistor

Product Summary:

BV_{DSS}	30V
$R_{DS(on)}$ (MAX.)	17m Ω
I_D	8.6A

Dual N Channel MOSFET

UIS, Rg 100% Tested

Pb-Free Lead Plating & Halogen Free

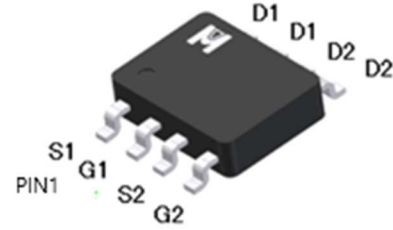
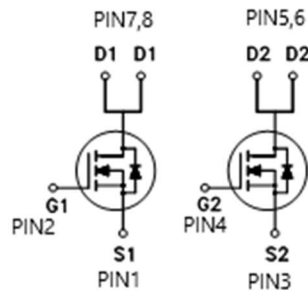

ABSOLUTE MAXIMUM RATINGS ($T_A = 25^\circ\text{C}$ Unless Otherwise Noted)

PARAMETERS/TEST CONDITIONS		SYMBOL	LIMITS	UNIT
Gate-Source Voltage		V_{GS}	± 20	V
Continuous Drain Current	$T_A = 25^\circ\text{C}$	I_D	8.6	A
	$T_A = 70^\circ\text{C}$		6.8	
Pulsed Drain Current ¹		I_{DM}	40	
Avalanche Current		I_{AS}	28	
Avalanche Energy	$L = 0.1\text{mH}$	E_{AS}	39.2	mJ
Repetitive Avalanche Energy ²	$L = 0.05\text{mH}$	E_{AR}	19.6	
Power Dissipation	$T_A = 25^\circ\text{C}$	P_D	2.00	W
	$T_A = 70^\circ\text{C}$		1.28	
Operating Junction & Storage Temperature Range		T_j, T_{stg}	-55 to 150	$^\circ\text{C}$

100% UIS testing in condition of $V_D=15\text{V}$, $L=0.1\text{mH}$, $V_G=10\text{V}$, $I_L=10\text{A}$, Rated $V_{DS}=30\text{V}$ N-CH

THERMAL RESISTANCE RATINGS

THERMAL RESISTANCE	SYMBOL	TYPICAL	MAXIMUM	UNIT
Junction-to-Case	$R_{\theta JC}$		25	$^\circ\text{C} / \text{W}$
Junction-to-Ambient ³	$R_{\theta JA}$		62.5	

¹Pulse width limited by maximum junction temperature.

²Duty cycle $\leq 1\%$

³62.5 $^\circ\text{C} / \text{W}$ when mounted on a 1 in² pad of 2 oz copper.



ELECTRICAL CHARACTERISTICS (T_J = 25 °C, Unless Otherwise Noted)

PARAMETER	SYMBOL	TEST CONDITIONS	LIMITS			UNIT
			MIN	TYP	MAX	
STATIC						
Drain-Source Breakdown Voltage	V _{(BR)DSS}	V _{GS} = 0V, I _D = 250μA	30			V
Gate Threshold Voltage	V _{GS(th)}	V _{DS} = V _{GS} , I _D = 250μA	1	1.5	3	
Gate-Body Leakage	I _{GSS}	V _{DS} = 0V, V _{GS} = ±20V			±100	nA
Zero Gate Voltage Drain Current	I _{DSS}	V _{DS} = 24V, V _{GS} = 0V			1	μA
		V _{DS} = 20V, V _{GS} = 0V, T _J = 125 °C			25	
On-State Drain Current ¹	I _{D(ON)}	V _{DS} = 10V, V _{GS} = 10V	8.6			A
Drain-Source On-State Resistance ¹	R _{DS(ON)}	V _{GS} = 10V, I _D = 8A		14.5	17	mΩ
		V _{GS} = 4.5V, I _D = 6A		21	26	
Forward Transconductance ¹	g _{fs}	V _{DS} = 5V, I _D = 8A		18		S
DYNAMIC						
Input Capacitance	C _{iss}	V _{GS} = 0V, V _{DS} = 15V, f = 1MHz		730		pF
Output Capacitance	C _{oss}			112		
Reverse Transfer Capacitance	C _{rss}			96		
Gate Resistance	R _g	V _{GS} = 15mV, V _{DS} = 0V, f = 1MHz		1.8		Ω
Total Gate Charge ^{1,2}	Q _g (V _{GS} =10V)	V _{DS} = 15V, V _{GS} = 10V, I _D = 8.6A		14.8		nC
	Q _g (V _{GS} =4.5V)			7.6		
Gate-Source Charge ^{1,2}	Q _{gs}			2.9		
Gate-Drain Charge ^{1,2}	Q _{gd}			4.2		
Turn-On Delay Time ^{1,2}	t _{d(on)}		V _{DS} = 15V, I _D = 1A, V _{GS} = 10V, R _{GS} = 6Ω		10	
Rise Time ^{1,2}	t _r			12		
Turn-Off Delay Time ^{1,2}	t _{d(off)}			20		
Fall Time ^{1,2}	t _f			12		
SOURCE-DRAIN DIODE RATINGS AND CHARACTERISTICS (T_C = 25 °C)						
Continuous Current	I _S				8.6	A
Pulsed Current ³	I _{SM}				40	
Forward Voltage ¹	V _{SD}	I _F = I _S , V _{GS} = 0V			1.2	V
Reverse Recovery Time	t _{rr}	I _F = I _S , dI _F /dt = 100A / μS		10		nS
Peak Reverse Recovery Current	I _{RM(REC)}			30		A
Reverse Recovery Charge	Q _{rr}				12	

¹Pulse test : Pulse Width $\leq 300 \mu\text{sec}$, Duty Cycle $\leq 2\%$.

²Independent of operating temperature.

³Pulse width limited by maximum junction temperature.

EMC will review datasheet by quarter, and update new version.



TYPICAL CHARACTERISTICS

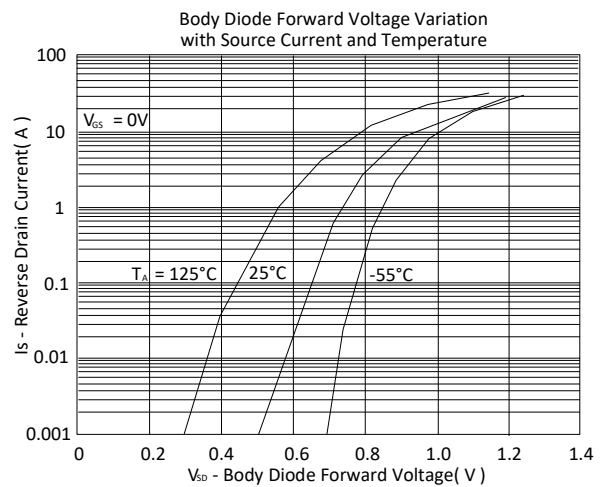
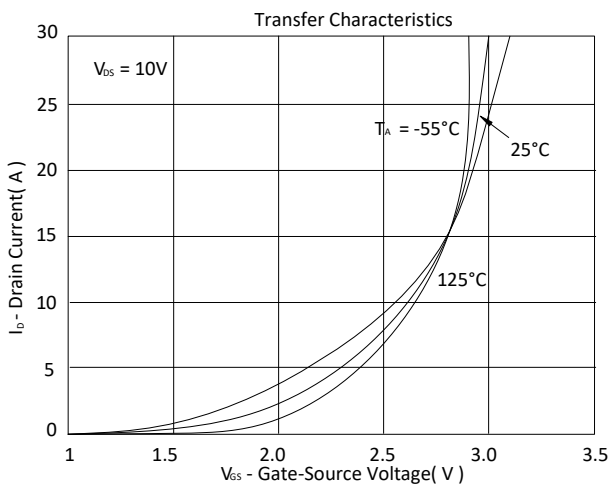
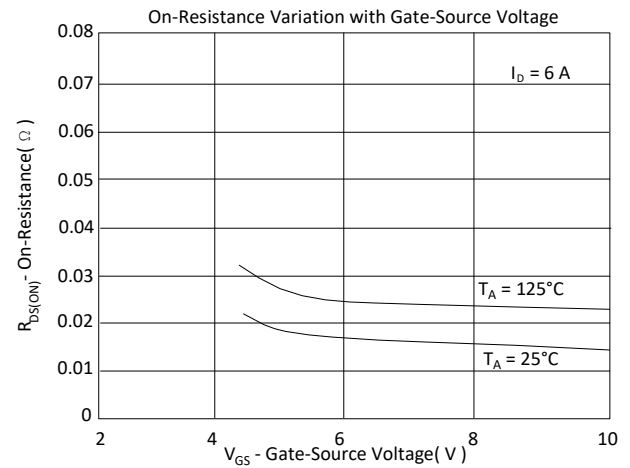
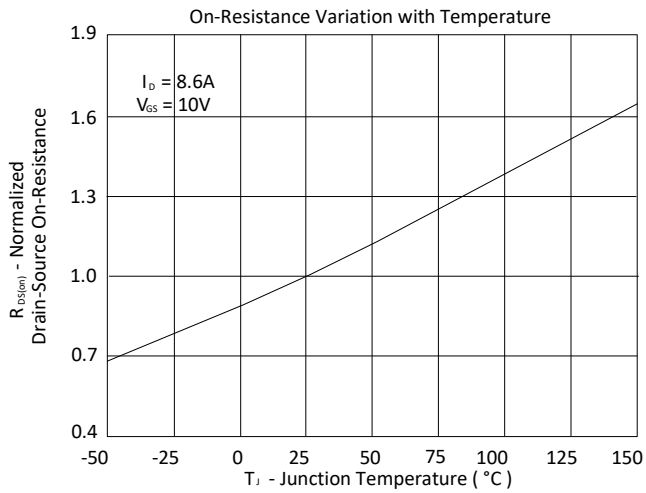
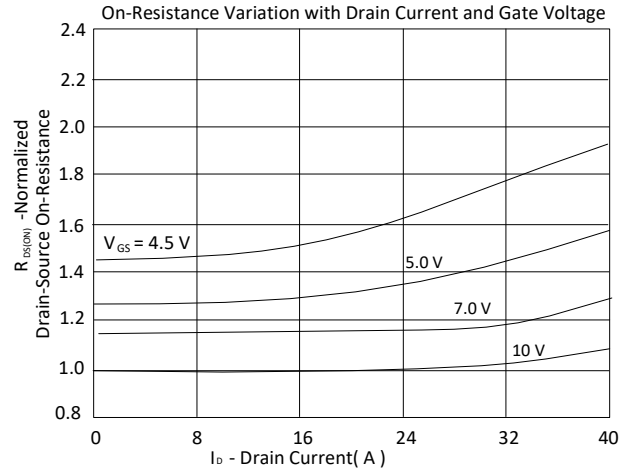
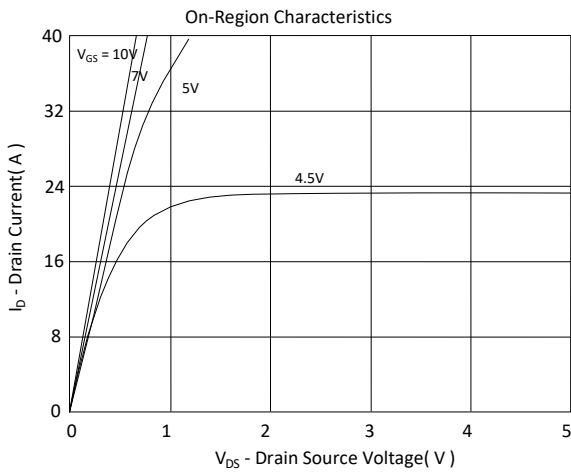

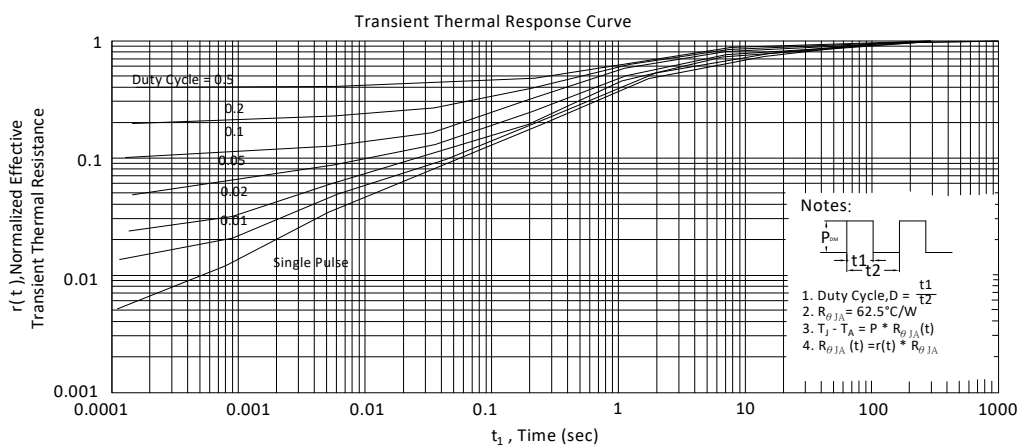
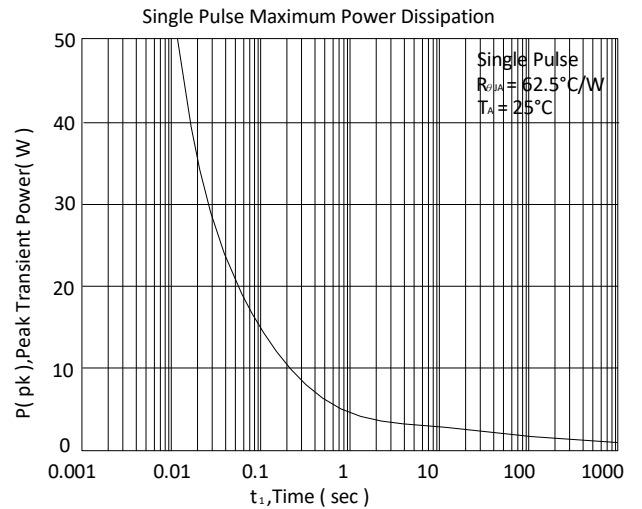
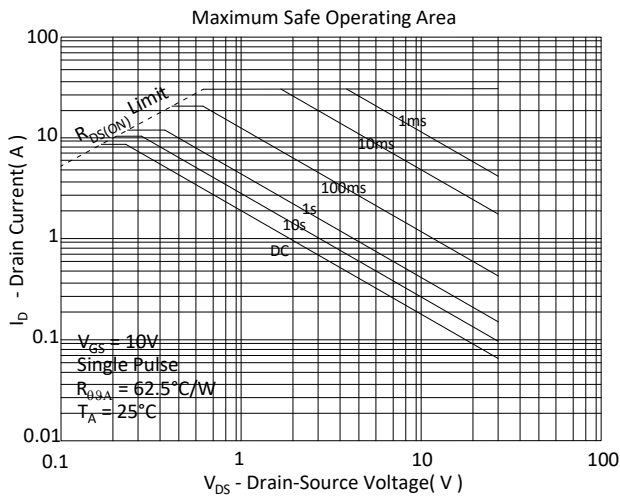
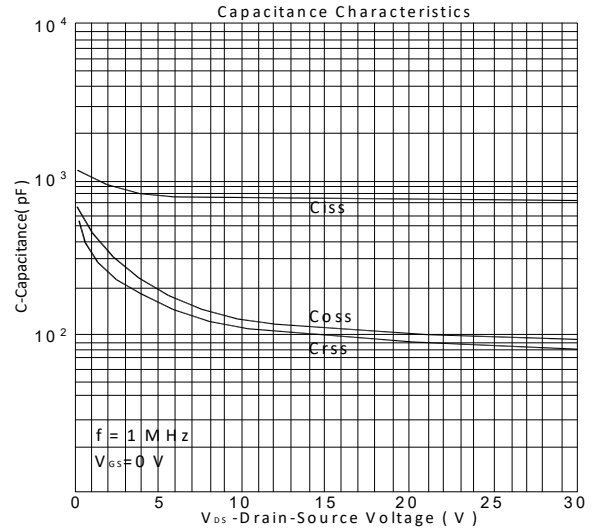
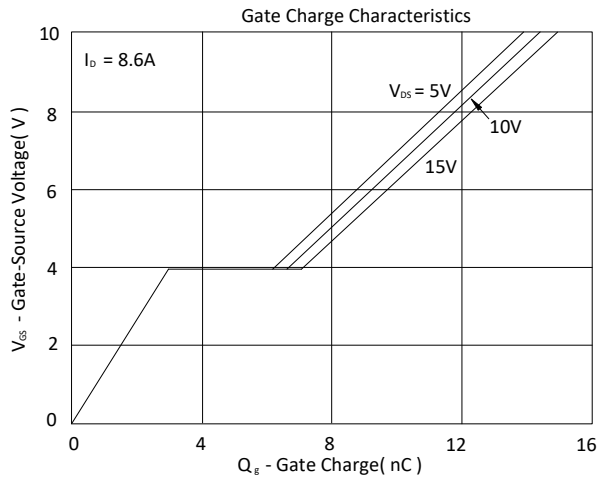

Ordering & Marking Information:

Device Name: EMB17A03G for SOP-8

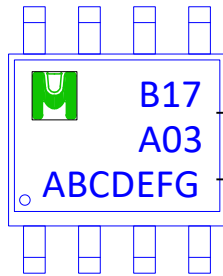

EMB17A03G: Device Name

ABCDEFGH: Date Code

A: Assembly House

B: Year(A:2008 B:2009 C:2010....)

C: Month(A:01 B:02 C:03 D:04 E:05 F:06 G:07 H:08 I:09 J:10 K:11 L:12)

DEFG: Serial No.

Outline Drawing

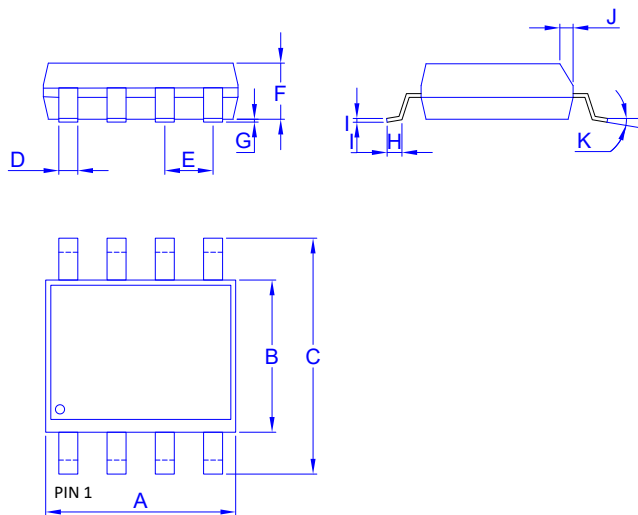

Dimension in mm

Dimension	A	B	C	D	E	F	G	H	I	J	K
Min.	4.70	3.80	5.80	0.31		1.35	0.01	0.40	0.10	0.25	0°
Typ.	4.90	3.90	6.00	0.41	1.27	1.55	0.18	0.60	0.20	0.30	
Max.	5.10	4.00	6.20	0.51		1.75	0.25	1.27	0.25	0.50	8°

Footprint

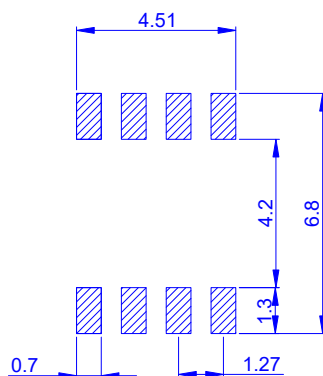



Tape&Reel Information:2500pcs/Reel

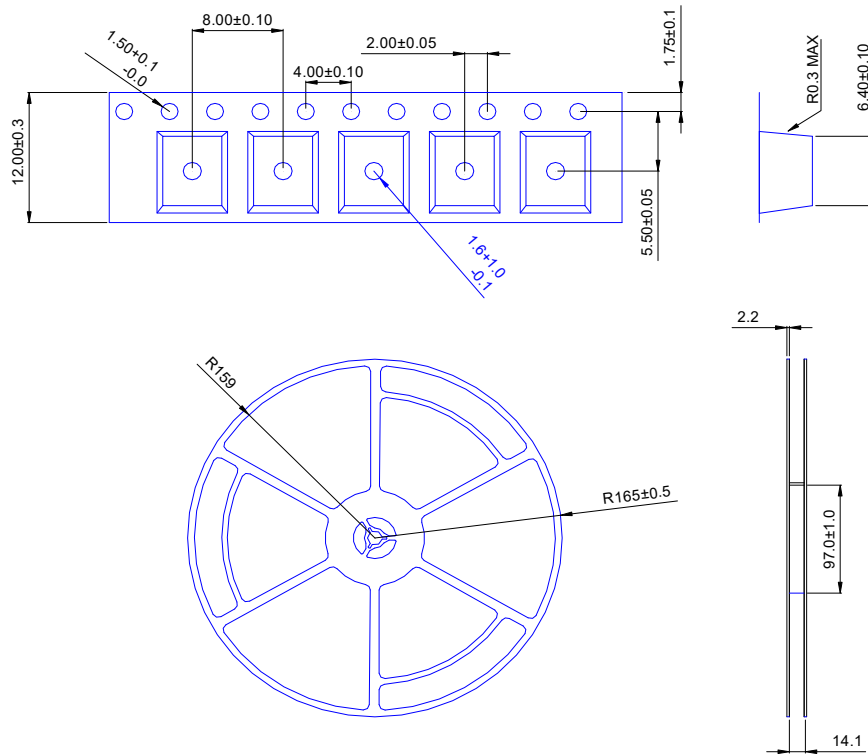

產品別	SOP-8
Reel 尺寸	13"
編帶方式	FEED DIRECTION 
前空格	25
後空格	50
裝箱數	
滿捲數量	2.5K
捲/內盒比	1 : 1
內盒滿箱數	2.5K
內/外箱比	10 : 1
外箱滿箱數	25K