

N-Channel Logic Level Enhancement Mode Field Effect Transistor

Product Summary:

BV _{DSS}	60V
R _{DS(on)} (MAX.)	8mΩ
I _D	14A

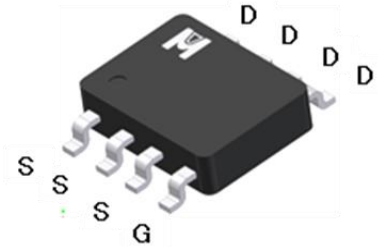
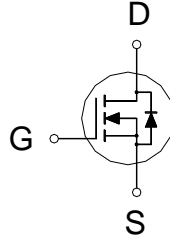

UIS, R_g 100% Tested

Pb-Free Lead Plating & Halogen Free



ABSOLUTE MAXIMUM RATINGS (T_A = 25 °C Unless Otherwise Noted)

PARAMETERS/TEST CONDITIONS		SYMBOL	LIMITS	UNIT
Gate-Source Voltage		V _{GS}	±20	V
Continuous Drain Current	T _A = 25 °C	I _D	14	A
	T _A = 70 °C		11	
Pulsed Drain Current ^{1,3}		I _{DM}	56	
Avalanche Current		I _{AS}	14	
Avalanche Energy	L = 0.1mH, I _D =14A, R _G =25Ω	E _{AS}	9.8	mJ
Repetitive Avalanche Energy ²	L = 0.05mH	E _{AR}	4.9	
Power Dissipation	T _A = 25 °C	P _D	2.5	W
	T _A = 70 °C		1.6	
Operating Junction & Storage Temperature Range		T _J , T _{stg}	-55 to 150	°C

THERMAL RESISTANCE RATINGS

THERMAL RESISTANCE	SYMBOL	TYPICAL	MAXIMUM	UNIT
Junction-to-Case	R _{θJC}		25	°C / W
Junction-to-Ambient ³	R _{θJA}		50	

¹Pulse width limited by maximum junction temperature.

²Duty cycle ≤ 1%

³50°C / W when mounted on a 1 in² pad of 2 oz copper.

ELECTRICAL CHARACTERISTICS (T_J = 25 °C, Unless Otherwise Noted)

PARAMETER	SYMBOL	TEST CONDITIONS	LIMITS			UNIT
			MIN	TYP	MAX	
STATIC						
Drain-Source Breakdown Voltage	V _{(BR)DSS}	V _{GS} = 0V, I _D = 250μA	60			V
Gate Threshold Voltage	V _{GS(th)}	V _{DS} = V _{GS} , I _D = 250μA	1.0	2.0	3.0	
Gate-Body Leakage	I _{GSS}	V _{DS} = 0V, V _{GS} = ±20V			±100	nA
Zero Gate Voltage Drain Current	I _{DSS}	V _{DS} = 48V, V _{GS} = 0V			1	μA
		V _{DS} = 40V, V _{GS} = 0V, T _J = 125 °C			25	
On-State Drain Current ¹	I _{D(ON)}	V _{DS} = 5V, V _{GS} = 10V	14			A
Drain-Source On-State Resistance ¹	R _{DS(ON)}	V _{GS} = 10V, I _D = 14A		7.1	8.0	mΩ
		V _{GS} = 4.5V, I _D = 10A		11.5	14	
Forward Transconductance ¹	g _{fs}	V _{DS} = 5V, I _D = 14A		48		S
DYNAMIC						
Input Capacitance	C _{iss}	V _{GS} = 0V, V _{DS} = 25V, f = 1MHz		2869		pF
Output Capacitance	C _{oss}			296		
Reverse Transfer Capacitance	C _{rss}			68		
Gate Resistance	R _g	V _{GS} = 15mV, V _{DS} = 0V, f = 1MHz		2.0		Ω
Total Gate Charge ^{1,2}	Q _g	V _{DS} = 30V, V _{GS} = 10V, I _D = 14A		38		nC
Gate-Source Charge ^{1,2}	Q _{gs}			17		
Gate-Drain Charge ^{1,2}	Q _{gd}			5.2		
Turn-On Delay Time ^{1,2}	t _{d(on)}	V _{DS} = 30V, I _D = 1A, V _{GS} = 10V, R _{GS} = 6Ω		20		nS
Rise Time ^{1,2}	t _r			80		
Turn-Off Delay Time ^{1,2}	t _{d(off)}			120		
Fall Time ^{1,2}	t _f			100		
SOURCE-DRAIN DIODE RATINGS AND CHARACTERISTICS (T_C = 25 °C)						
Continuous Current	I _S				14	A
Pulsed Current ³	I _{SM}				56	
Forward Voltage ¹	V _{SD}	I _F = I _S , V _{GS} = 0V			1.3	V
Reverse Recovery Time	t _{rr}	I _F = 14A, dI _F /dt = 100A / μS		28		nS
Reverse Recovery Charge	Q _{rr}				145	

¹Pulse test : Pulse Width ≤ 300 μsec, Duty Cycle ≤ 2%.

²Independent of operating temperature.

³Pulse width limited by maximum junction temperature.

Ordering & Marking Information:

Device Name: EMB08N06G for SOP-8

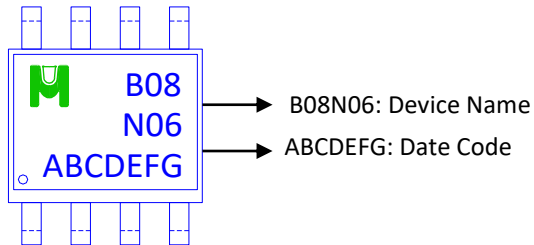

Outline Drawing

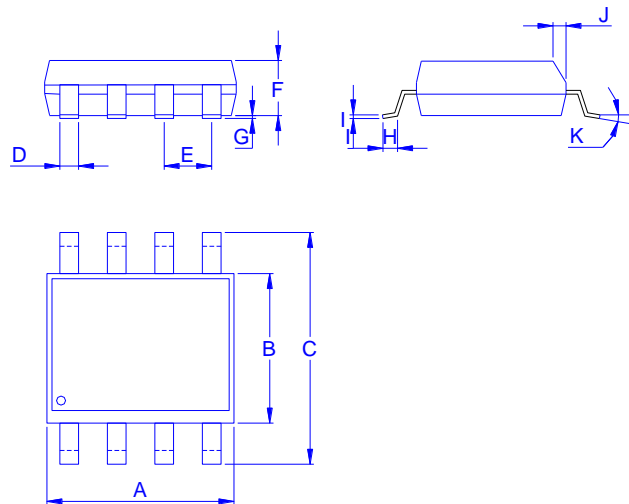

Dimension in mm

Dimension	A	B	C	D	E	F	G	H	I	J	K
Min.	4.70	3.70	5.80	0.33		1.20	0.08	0.40	0.19	0.25	0°
Typ.					1.27						
Max.	5.10	4.10	6.20	0.51		1.62	0.28	0.83	0.26	0.50	8°

Footprint

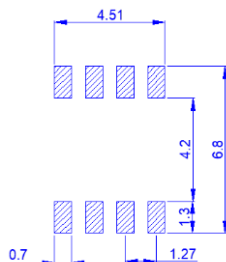



TYPICAL CHARACTERISTICS

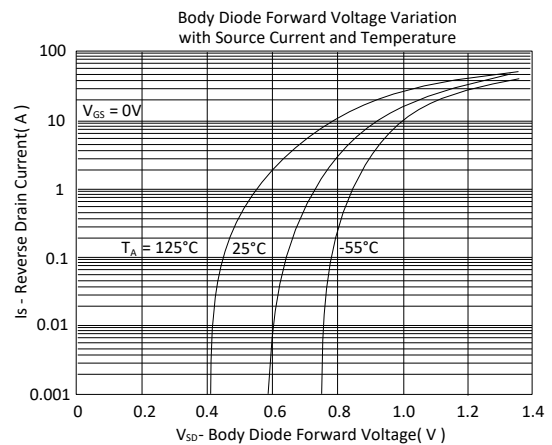
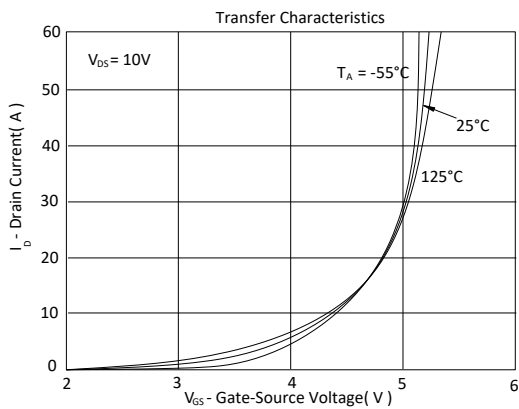
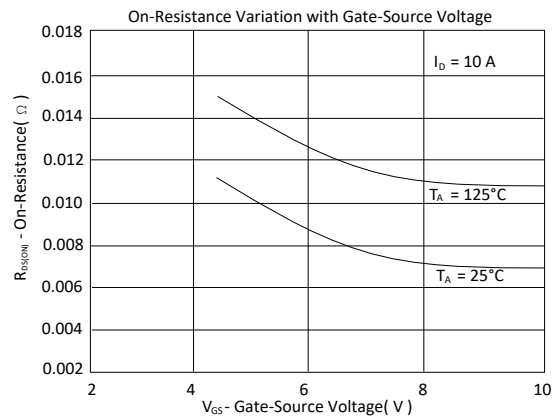
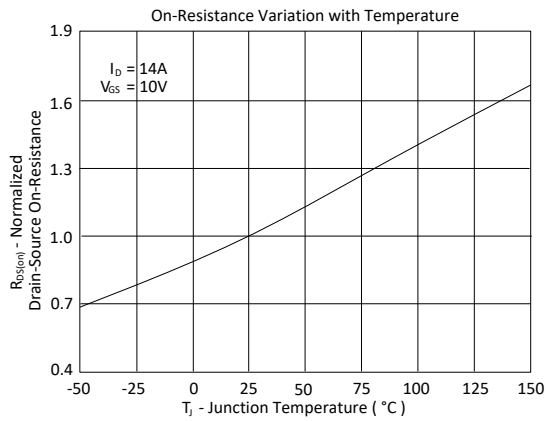
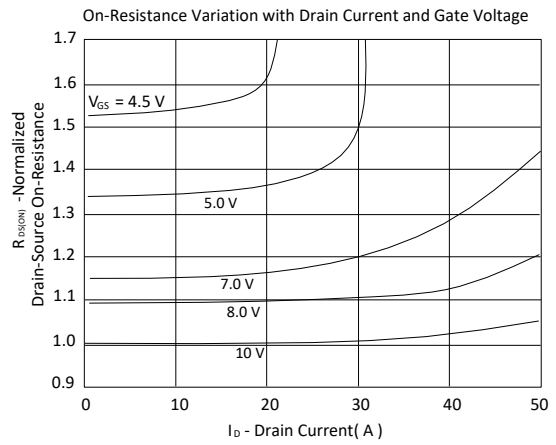
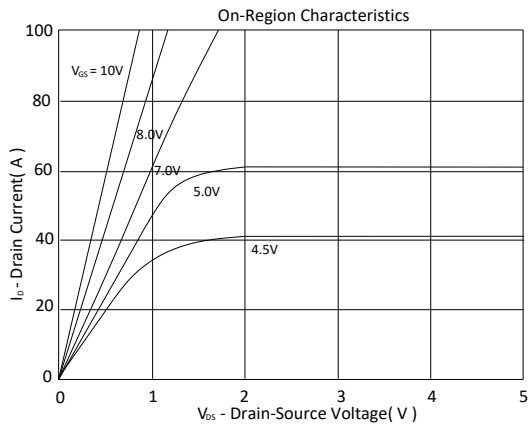

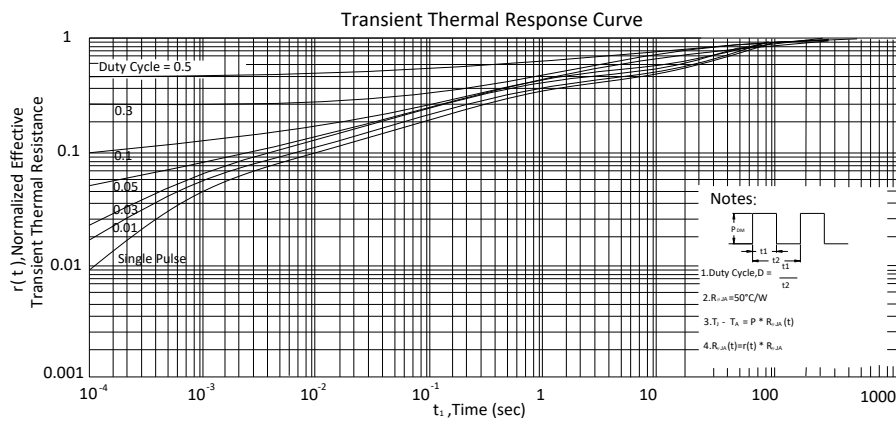
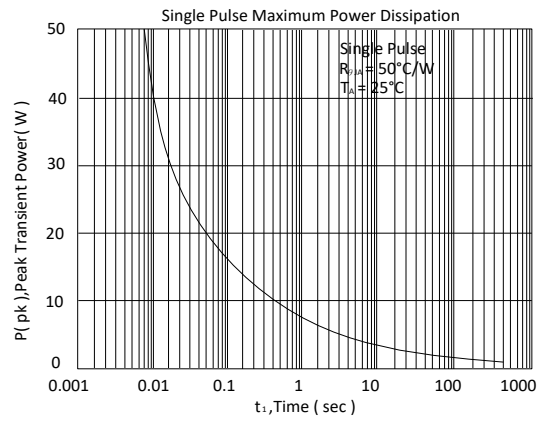
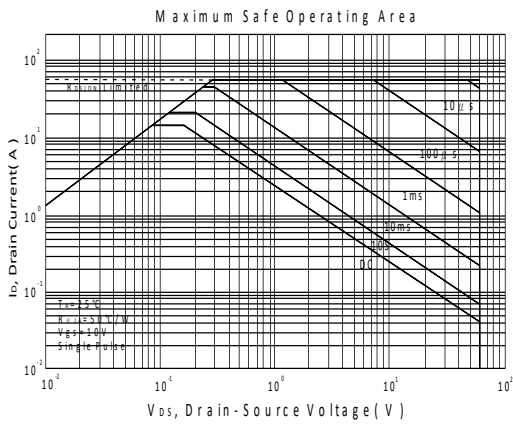
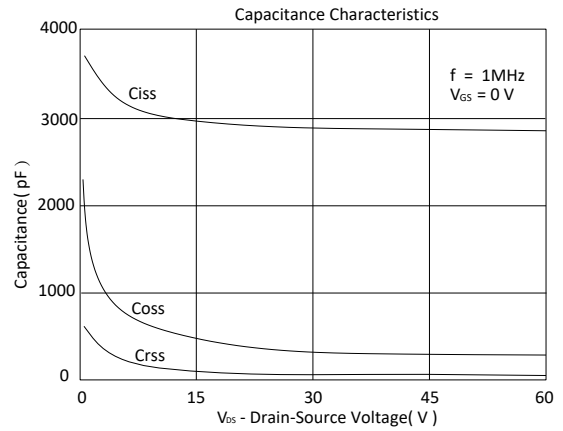
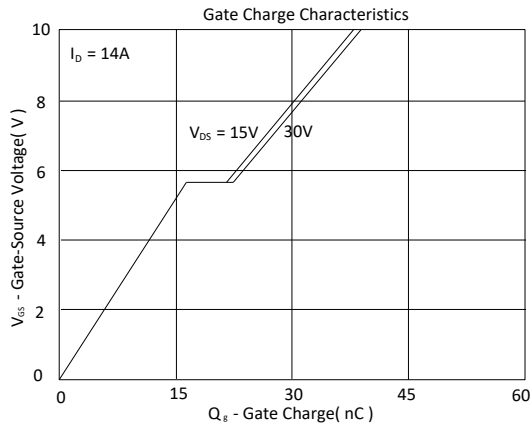

◆ Tape&Reel Information:2500pcs/Reel

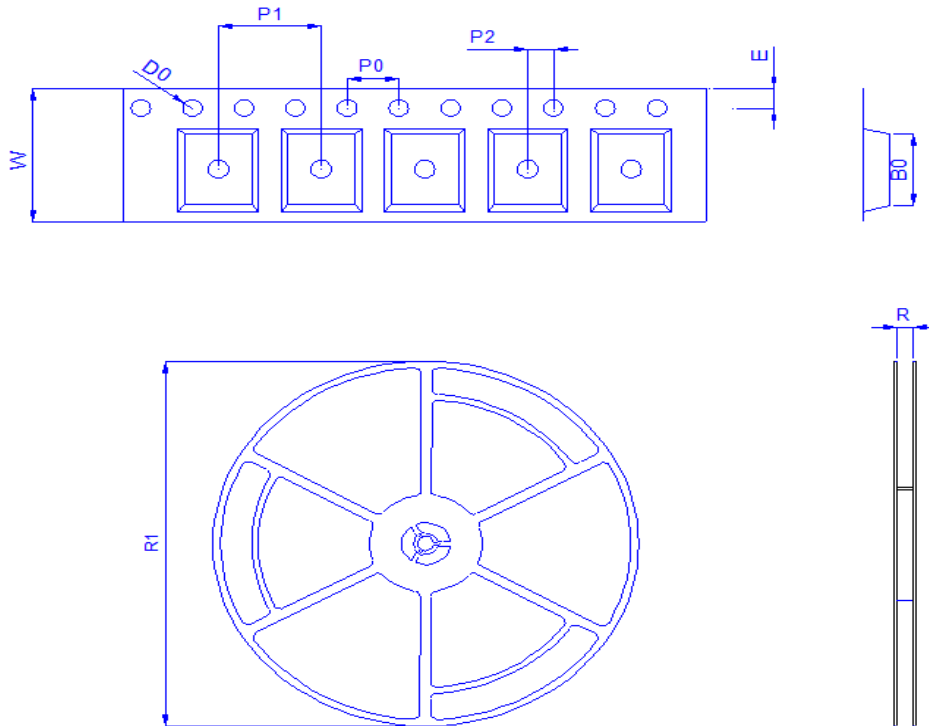

產品別	(P)SOP-8
Reel 尺寸	13"
編帶方式	<p>FEED DIRECTION</p> <p>←</p>

Dimension in mm

Dimension	Carrier tape							Reel	
	B0	D0	E	P0	P1	P2	W	R	R1
Typ.	6.50	1.50	1.75	4.00	8.00	2.00	12.00	12.40	330.00
±	0.40	0.20	0.20	0.20	0.20	0.20	0.50	REF	REF