

# HV Start-up Green-mode PWM Converter with Brown-Out Protection

## General Description

EM8565D is a high performance, low cost, HV Start-up, current mode PWM controller with green mode power saving. It integrates an advanced PWM and 650V power MOSFET a single package, provides the users a superior power designs with higher efficiency, reduced size, improved reliability, and lower power system cost.

The EM8565D also features more protection like Over Load Protection (OLP) and Over Voltage Protection (OVP) to prevent circuit damage occurred under abnormal conditions. And has line under-voltage protection (Brown-out Protection).

## Ordering Information

Part Number	Package	Remark
EM8565DS7	DIP-7	

## Features

- 650V High Voltage Start up Circuit
- Current Mode Control
- Soft Start Function
- Built-in Slope Compensation
- Internal Leading-edge Blanking
- Brown in/out Protection
- Over Voltage Protection (OVP) on VCC pin
- Over Load Protection (OLP)
- Cycle-by-cycle Current Limit
- Feedback Open Protection
- Internal Over Temperature Protection (OTP)
- Constant Output Power Limit (Full AC Input Range)
- Excellent EMI performance

## Applications



- LCD Monitor Power
- Auxiliary Power Supply for PC, Server, LCD TV
- Open-Frame SMPS
- General Adapter and Charger

## Typical Application Circuit 1

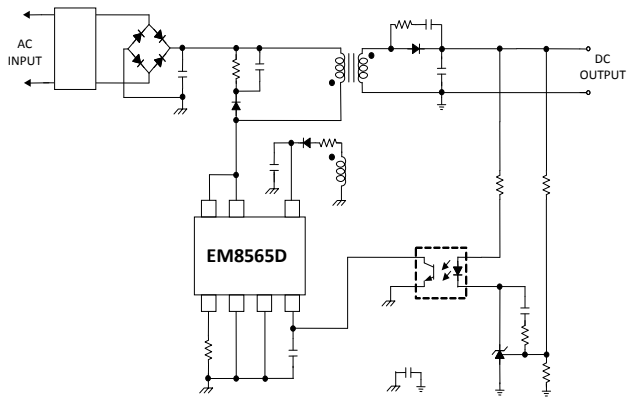

## Typical Application Circuit 2

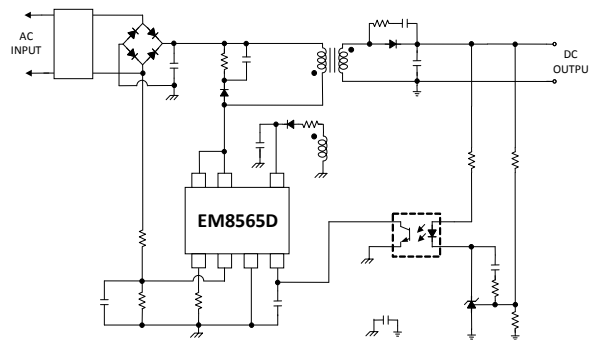

## Pin Configuration

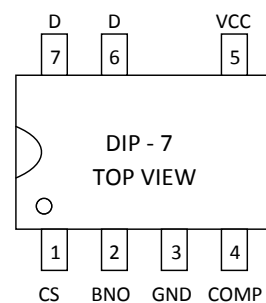

**Pin Assignment**

Pin Name	Pin Number	Pin Function
	DIP-7	
CS	1	Senses the primary current.
BNO	2	Line voltage detection. Use for brown-out protection.
GND	3	Ground.
COMP	4	Voltage feedback pin. By connecting a photo-coupler to close the control loop and achieve the regulation.
VCC	5	IC Power Supply Pin.
D	6,7	For start-up, the pin is also HV Power MOSFET drain Pin.

**Function Block Diagram**

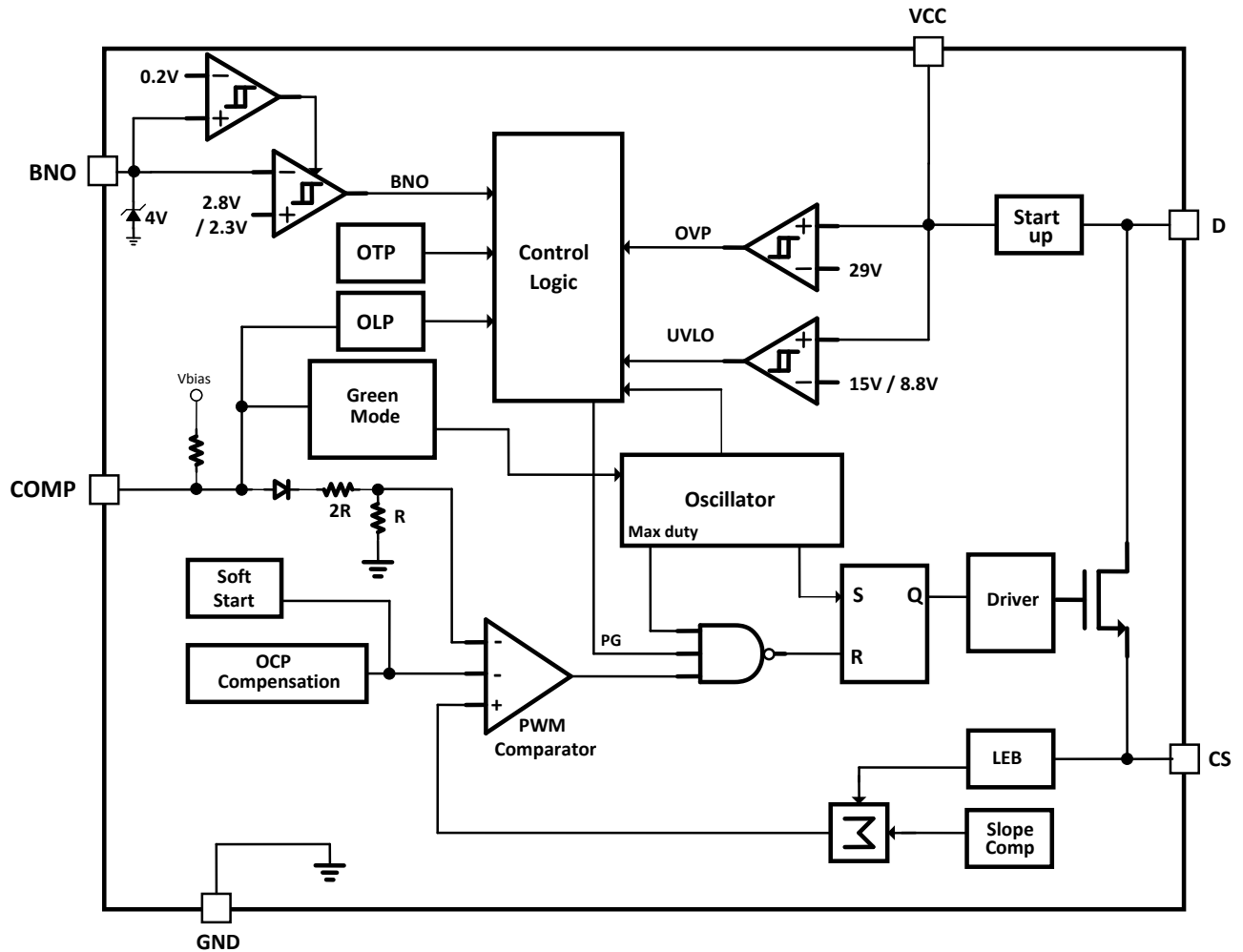



**Absolute Maximum Ratings** (Note1)

● Supply Input Voltage, VCC -----	32V
● D pin-----	650V
● BNO, COMP, CS Pin -----	- 0.3V to 6.5V
● Power Dissipation, PD @ TA = 25°C	
DIP 7 -----	1.5W
● Package Thermal Resistance	
DIP 7 -----	80°C/W
● Junction Temperature -----	150°C
● Lead Temperature (Soldering, 10 sec.) -----	260°C
● Storage Temperature Range -----	- 65°C to 150°C
● ESD Susceptibility (Note2)	
HBM (Human Body Mode) -----	2KV
MM (Machine Mode) -----	250V

**Recommended Operating Conditions** (Note3)

● Supply Input Voltage, VCC -----	9V to 27V
● VCC Capacitor -----	10uF to 47uF
● Junction Temperature Range-----	- 40°C to 125°C
● Ambient Temperature Range-----	- 40°C to 85°C

**Electrical Characteristics**

 ( $V_{CC}=16V$ ,  $T_A=25^{\circ}C$ , unless otherwise specified)

Parameter	Symbol	Test Conditions	Min	Typ	Max	Units
<b>VCC Section</b>						
VCC OVP Protect voltage	$V_{OVP}$		27.5	29	30.5	V
Start up current	$I_{START}$	$V_{CC}=V_{TH-ON}-0.5V$	-	45	65	$\mu A$
VCC On Threshold Voltage	$V_{TH-ON}$		13.5	15	16.5	V
VCC Off Threshold Voltage	$V_{TH-OFF}$		8	8.8	9.5	V
Operating Supply Current 1	$I_{CC-OP1}$	$V_{CC}=15V$ , $V_{COMP}=0V$	-	0.7	2	mA
Operating Supply Current 2	$I_{CC-OP2}$	$V_{CC}=15V$ , $V_{COMP}=3V$	-	2	-	mA
Operating Supply Current 3	$I_{CC-OP3}$	$V_{CC}=15V$ , Protection triggered	-	0.4	-	mA
<b>D Section</b>						
HV Current Source	$I_{HV}$	$V_{CC}=V_{TH-ON}-0.5V$ $V_D=50V$		1		mA
Drain to Source Breakdown voltage	$B_{VDSS}$		650			V
Drain leakage current	$I_{LC}$	$V_{CC}=V_{TH-ON}+0.5V$ $V_D=650V$ , PWM off			50	$\mu A$
ON-Resistance	$R_{DS-ON}$			2.3		$\Omega$
Switching time	$T_F$				70	nS
<b>Current-Sense Section</b>						
Maximum Internal Current Setpoint	$V_{CSLim}$	OCP at 36% Duty	0.85	0.9	0.95	V
		OCP at Zero on-Duty	0.62	0.65	0.68	V
Leading Edge Blanking Time	$T_{LEB}$		300	380	460	nS
Propagation Delay Time	$T_{PD}$			100		nS
Soft-Start Period	$T_{SS}$			3.5		mS
<b>Internal Oscillator</b>						
Oscillation Frequency	$f_{OSC}$		94	100	106	KHz
Jitter Percentage	$P_{JITTER}$			+/-4		%
Jitter Period	$T_{JITTER}$			2.6		mS
Maximum Duty	$D_{max}$			75		%
Green mode minimum frequency	$f_{OSC-G}$			26		KHz
Frequency variation vs. VCC	$f_{DV}$	$V_{CC}=11V$ to $25V$			3	%

Frequency variation vs. Temperature	$f_{DT}$	-20°C to 105°C (Note4)			3	%
<b>COMP Section</b>						
COMP short to GND current	$I_{COMP}$	$V_{COMP}=0V$	150	250	350	uA
Open loop COMP voltage	$V_{COMP}$	COMP pin open		5.2		V
COMP voltage to CS voltage Attenuation	$A_V$		1 / 2.5	1 / 3	1 / 3.5	V/V
Green mode COMP Threshold Voltage	$V_{COMP-G}$			2.8		V
COMP voltage for zero duty	$V_{COMP-ZD}$			1.3		V
<b>BNO Section</b>						
Brown-in threshold	$V_{BNO-IN}$		2.6	2.8	3.0	V
Brown-out threshold	$V_{BNO-OUT}$		2.1	2.3	2.5	V
BNO function disable threshold	$V_{BNO-DIS}$		0.15	0.2	0.25	V
<b>Protection Section</b>						
Open loop protection delay time	$T_{delay}$			56		mS
Open loop protection COMP Trip voltage	$V_{OLP}$			4.0		V
Internal Temperature Shutdown	$T_{SD}$			150		°C

**Note 1.** Stresses listed as the above “Absolute Maximum Ratings” may cause permanent damage to the device. These are for stress ratings. Functional operation of the device at these or any other conditions beyond those indicated in the operational sections of the specifications is not implied. Exposure to absolute maximum rating conditions for extended periods may remain possibility to affect device reliability.

**Note 2.** Devices are ESD sensitive. Handling precaution is recommended.

**Note 3.** The device is not guaranteed to function outside its operating conditions.

**Note 4.** Guaranteed by design.

Typical Operating Characteristics

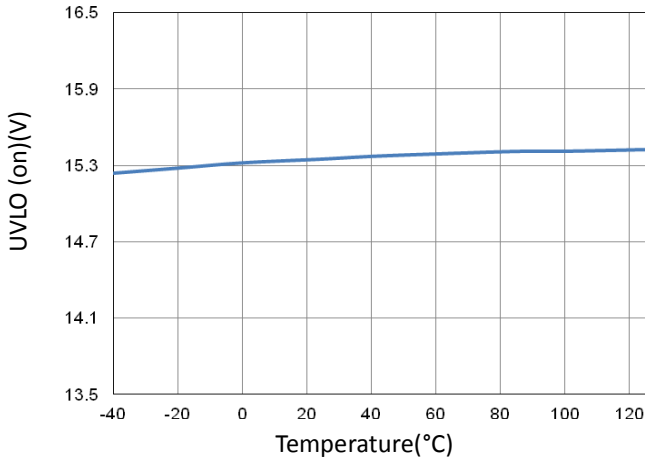

Fig1. UVLO (on) vs. Temperature.

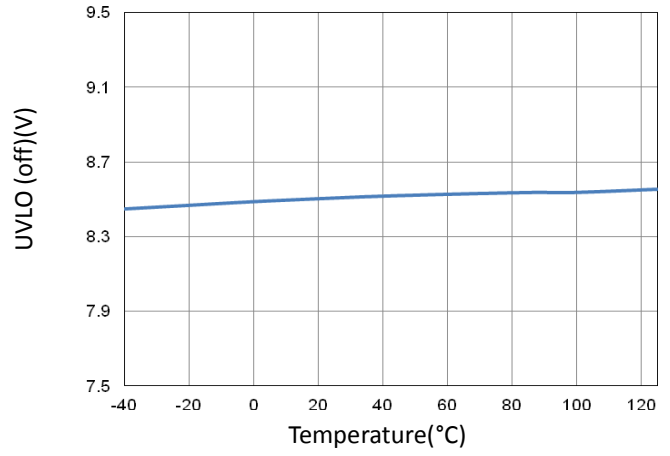

Fig2. UVLO (off) vs. Temperature

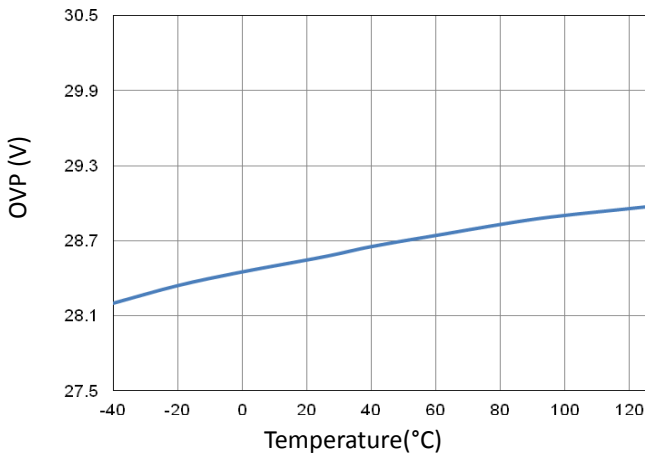

Fig3. OVP vs. Temperature.

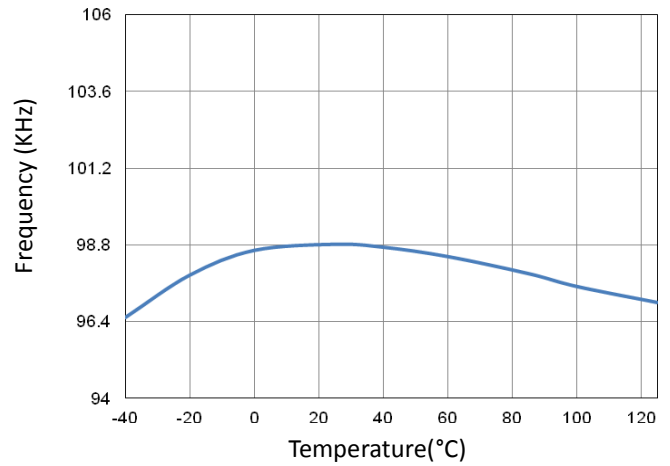

Fig4. Frequency vs. Temperature.

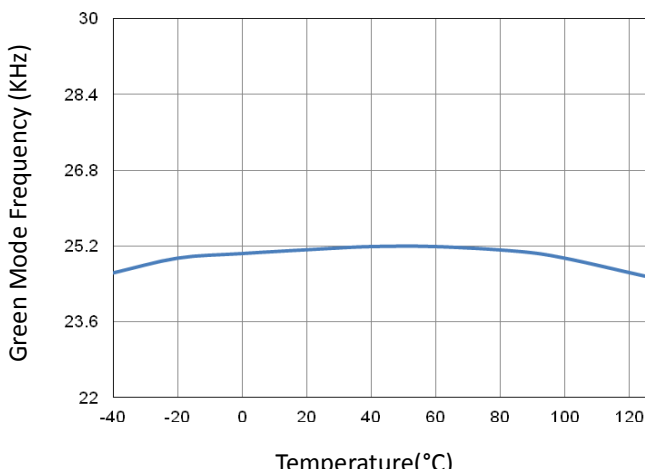

Fig5. Green Mode Frequency vs. Temperature.

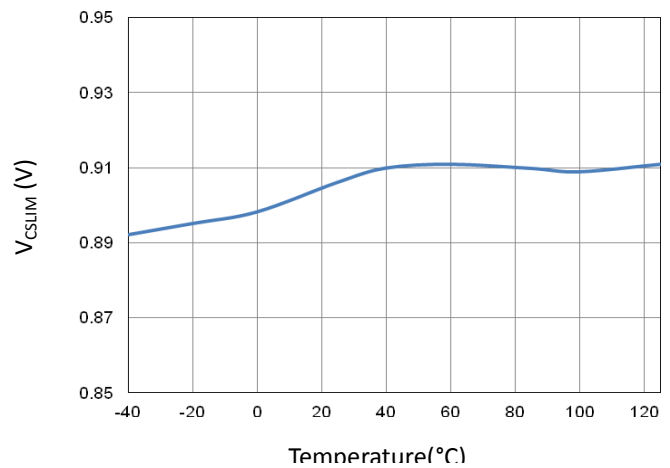

Fig6. VCSLIM vs. Temperature.

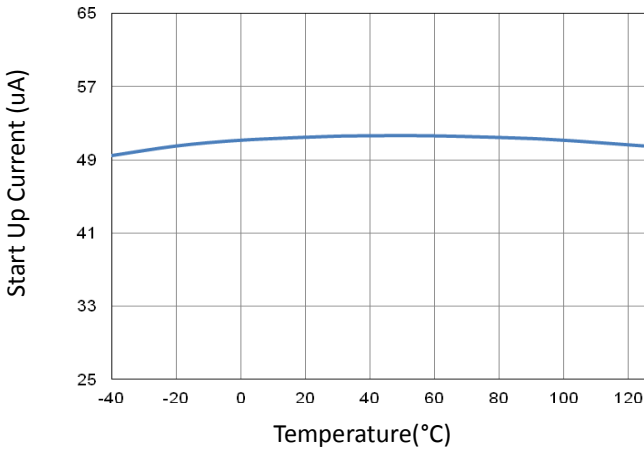

Fig7. Start Up Current vs. Temperature.

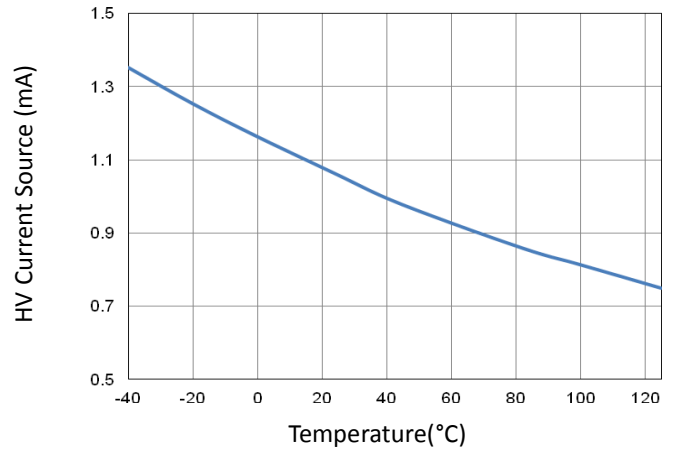

Fig8. HV Current Source vs. Temperature.

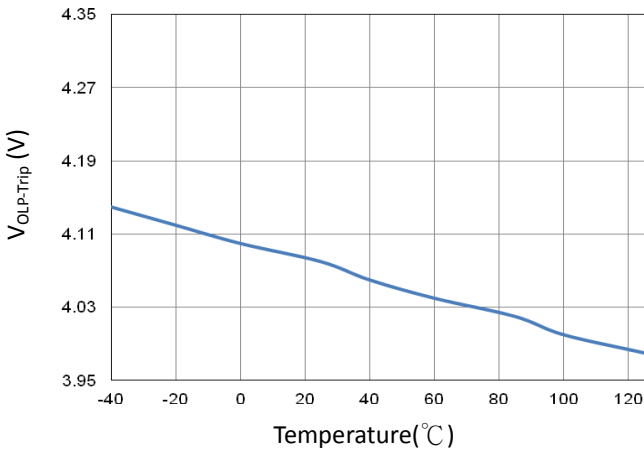

Fig9. V<sub>OLP-Trip</sub> vs. Temperature.

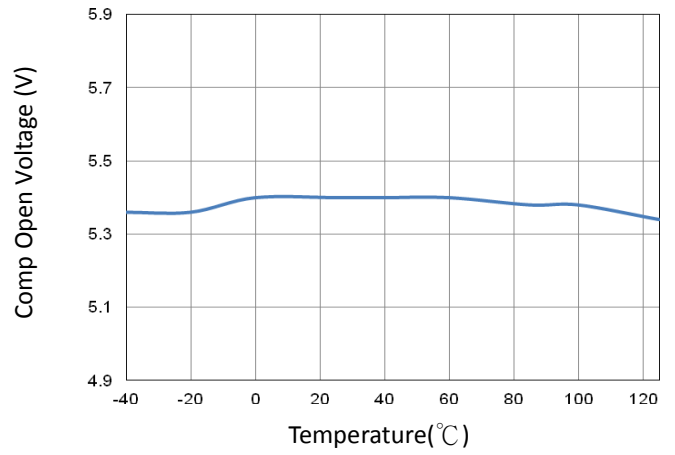

Fig10. Comp Open Voltage vs. Temperature.

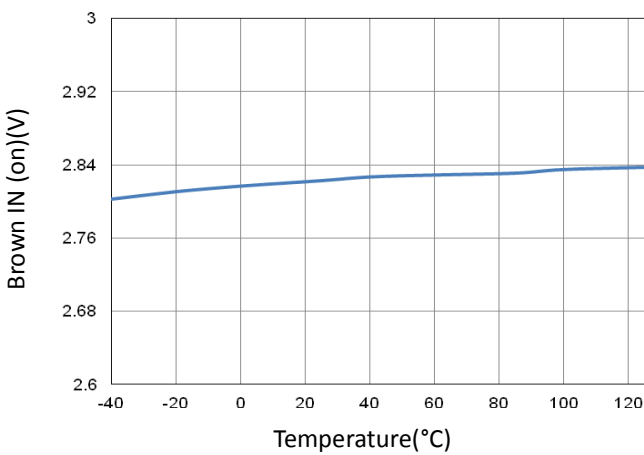

Fig11. Brown In (on) vs. Temperature

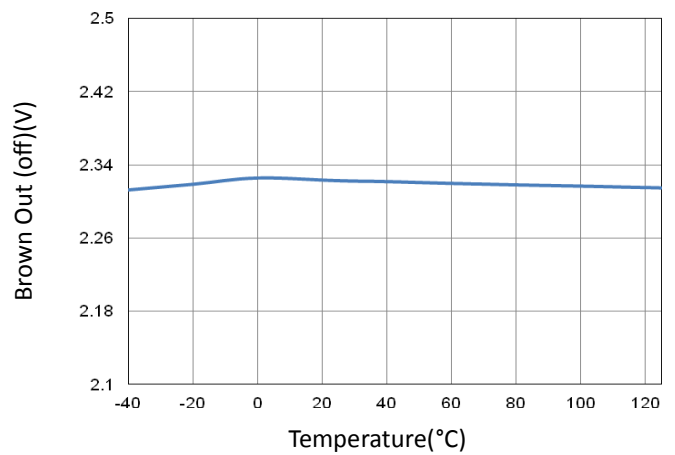

Fig12. Brown Out (off) vs. Temperature

## Functional Description

### UVLO

An UVLO comparator is implemented in EM8565D to monitor the VCC pin voltage. As shown in Fig. 13, a hysteresis is built in to prevent the shutdown from the voltage drop during startup. The UVLO (on) and UVLO (off) are setting at 15V and 8.8V, respectively.

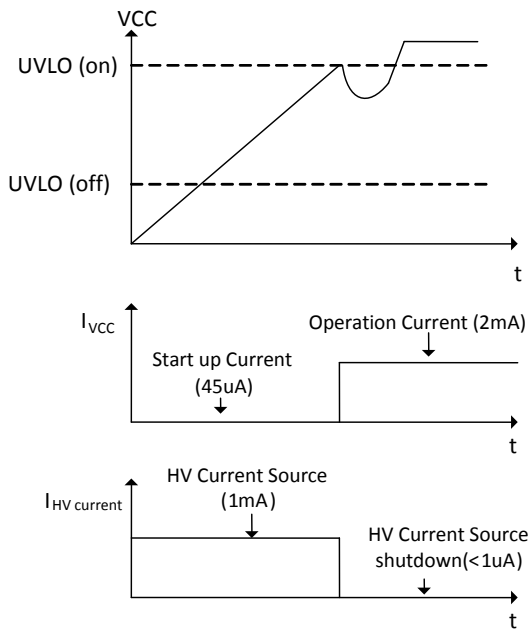

Fig. 13

### Startup Operation

Fig. 14 shows a typical HV startup circuit and transformer auxiliary winding for the EM8565D application, it consumes only startup current (typical 45uA) and the startup current drawn from the HV pin to charge the VCC capacitor (C<sub>VCC</sub>). When VCC reaches UVLO (on) voltage, EM8565D begins switching and the HV startup current switches off. Then, the power required is supplied from the transformer auxiliary winding. The hysteresis of UVLO (off) provides more holdup time, which allows using a small capacitor for VCC.

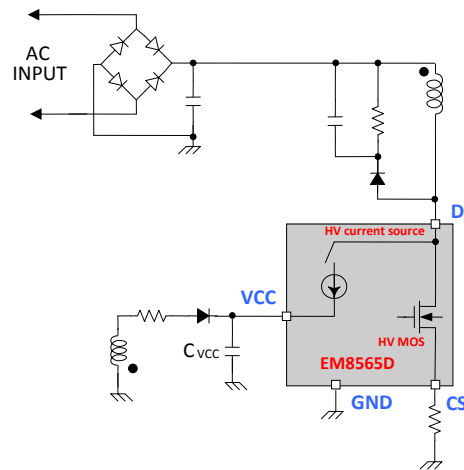

Fig. 14

### Switching Frequency

To guarantee accurate frequency, EM8565D is trimmed to 6% tolerance. The internal oscillator also generates slope compensation, 75% maximum duty limit.

### Leading Edge Blanking (LEB)

Fig.15 shows an each time the power MOSFET turn on, the MOSFET C<sub>oss</sub>, secondary rectifier reverse recovery current and gate driver sourcing current comprise the current spike. To avoid premature termination of the switching pulse, a leading edge blanking time is built in. During the blanking time (380nS), the PWM comparator is off and cannot switch off the gate driver.

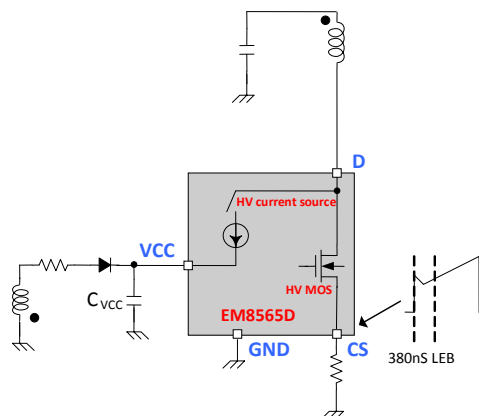

Fig. 15



**Soft Start**

The EM8565D has an internal soft-start circuit that increases cycle-by-cycle current limit comparator inverting input voltage slowly after it starts. The typical soft-start time is 3.5mS. The pulse width to the power MOSFET is progressively increased to establish the correct working conditions for transformers, rectifier diodes and capacitors. The voltage on the output capacitors is progressively increased with the intention of smoothly establishing the required output voltage. It also helps prevent transformer saturation and reduces the stress on the secondary diode during startup.

**Slope compensation**

In the conventional application, the problem of the stability is a critical issue for current mode controlling, when it operates in high than 50% of the duty cycle. The EM8565D built in saw-tooth slope compensation. So it requires no extra component.

**Brown-In/Out Function**

The EM8565D has a built-in internal brown-in/out protection comparator monitoring voltage of BNO pin. Fig. 16 shows a resistive divider with low-pass filtering for line-voltage detection on the BNO pin.

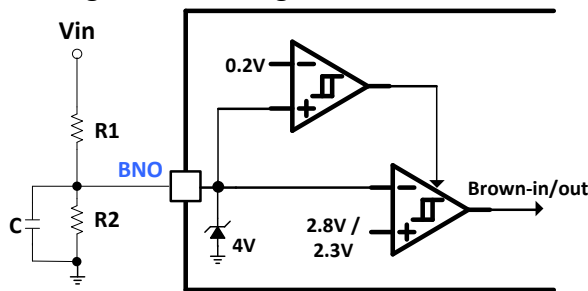

Fig. 16

If the BNO pin voltage is lower than 2.3V, the PWM gate is disabled to protect the system from over current. If the BNO pin increases above 2.8V, the EM8565D starts up.

If the BNO pin voltage is lower than 0.2V, the Brown-in/out function is disabled to allow the EM8565D to start up.

**Deep Burst Mode Operation**

At no load or light load condition, majority of the power dissipation in switching power supply is from switching loss on the power MOSFET, the core loss of the transformer and the loss on the snubber. The magnitude of power loss is in proportion to the number of switching events within a fixed period of time. Reducing switching events leads reduction on the power loss and conserves the energy.

The EM8565D adjusts the switching mode according to the load condition, the COMP pin voltage drops below Deep Burst mode in-threshold level (typical 1.3V). Device enters Deep Burst Mode Control. The Gate drive output remains at off state to minimize the switching loss and reduces the standby power consumption. And when the COMP pin voltage exceed the burst mode on threshold level (typical 1.4V). The Gate drive output starts active. The COMP pin voltage immediately increases if there is a high load. When the COMP pin voltage exceed the Deep Burst mode out-threshold level (typical 1.5V), the device goes to normal mode. During the Deep Burst mode, the CS level is controlled to 0.3V. Fig. 17 shows the signals of Deep Burst mode.

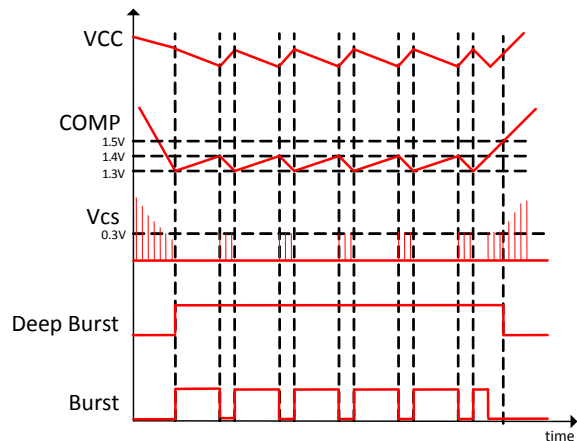

Fig. 17

**Protection**

The EM8565D provides many protection functions that intend to protect system from being damaged. All the protection functions are listed as below:

● **Cycle-by-cycle current limit**

The EM8565D has over-current protection thresholds. It is for cycle-by-cycle current limit, which turns off MOSFET for the remainder of the switching cycle when the sensing voltage of MOSFET current reaches the threshold.

● **Over-load / Open-loop Protection (OLP)**

When feedback loop is open, as shown in Fig. 18, no current flows through the opto-coupler transistor, the EM8565D pulls up the COMP pin voltage to 5.2V.

When the COMP pin voltage is above 4.0V longer than 56mS, OLP is triggered. This protection is also triggered when the SMPS output drops below the normal value longer than 56mS due to the overload condition.

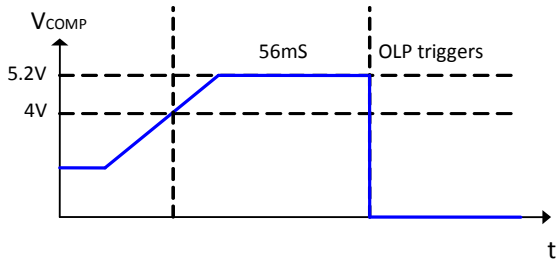
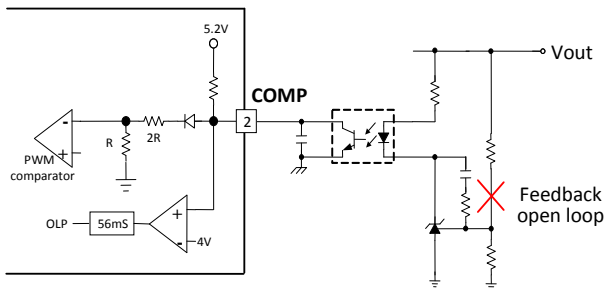

Fig. 18

**EM8565D**

● **Over Voltage Protection (OVP) on VCC**

The EM8565D are implemented an Over-Voltage-Protection (OVP) on VCC. Whenever the VCC voltage is high than the OVP threshold voltage (29V), the output gate drive will be shutdown to stop the switching of the power MOSFET until the next UVLO (on).

The Over-Voltage-Protection on VCC function in EM8565D is an auto-restart type protection. If the OVP condition is not released, the VCC will tripped the OVP level again and re-shutdown the gate output. The VCC is working as a hiccup mode as shown in Fig. 19. On the other hand, if the OVP condition is removed, the VCC level will go back to normal level and the output will automatically return to the normal operation.

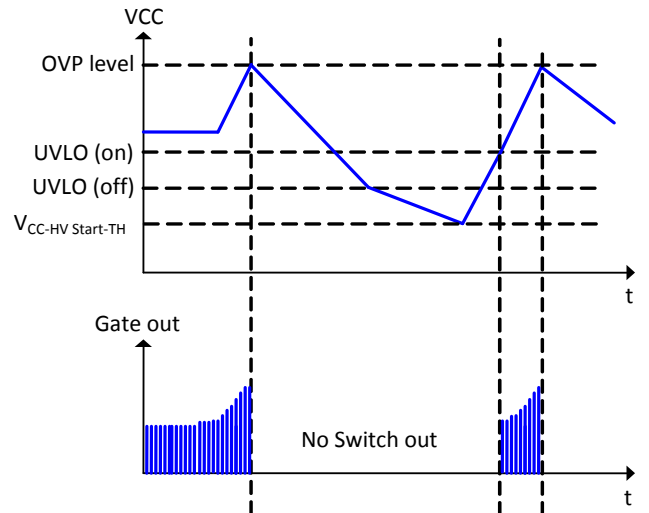

Fig. 19

● **Internal Over-Temperature Protection (OTP)**

Internal 150°C comparator will provide over temperature protection (OTP). OTP will not shutdown system. It stops the system from switching until the VCC is below the UVLO (off) threshold voltage, the system will hiccup.

## Ordering & Marking Information

Device Name: EM8565DS7 for DIP-7

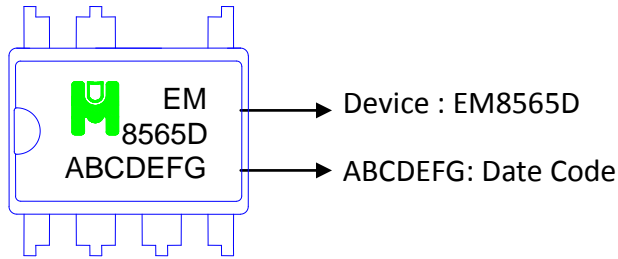

## Outline Drawing

DIP-7

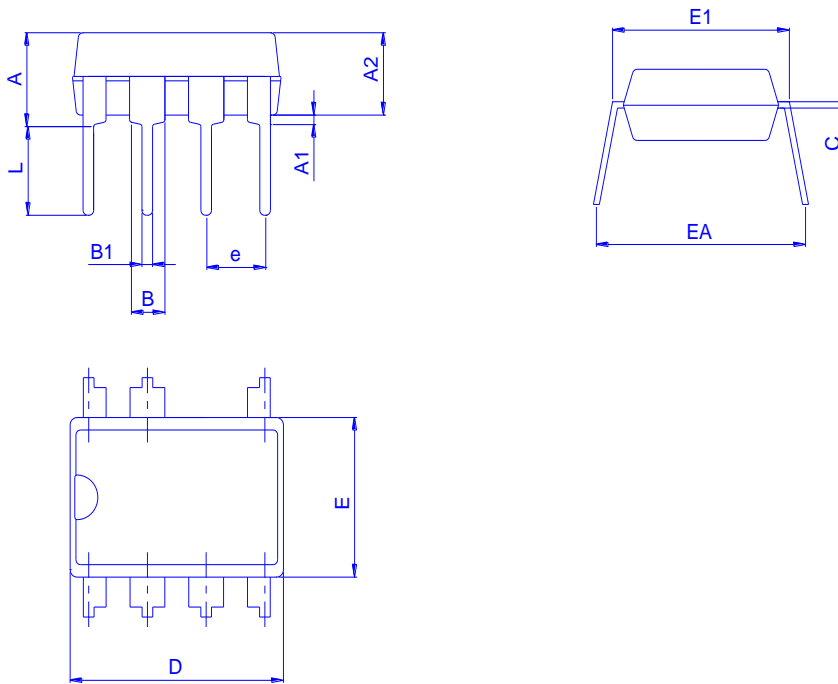

Dimension in mm

Dimension	A	A1	A2	B	B1	C	D	E	E1	EA	e	L
Min.		0.381	3.17				9.01	6.22	7.36	8.5		2.92
Typ.				1.524	0.457	0.254					2.54	
Max.	5.334		3.429				10.16	6.53	7.87	9.53		3.81